

Errata

Title & Document Type: 89441V VSB/QAM Signal Analyzer Operator's Guide

Manual Part Number: 89441-90061

Revision Date: September 1997

HP References in this Manual

This manual may contain references to HP or Hewlett-Packard. Please note that Hewlett-Packard's former test and measurement, semiconductor products and chemical analysis businesses are now part of Agilent Technologies. We have made no changes to this manual copy. The HP XXXX referred to in this document is now the Agilent XXXX. For example, model number HP8648A is now model number Agilent 8648A.

About this Manual

We've added this manual to the Agilent website in an effort to help you support your product. This manual provides the best information we could find. It may be incomplete or contain dated information, and the scan quality may not be ideal. If we find a better copy in the future, we will add it to the Agilent website.

Support for Your Product

Agilent no longer sells or supports this product. You will find any other available product information on the Agilent Test & Measurement website:

www.tm.agilent.com

Search for the model number of this product, and the resulting product page will guide you to any available information. Our service centers may be able to perform calibration if no repair parts are needed, but no other support from Agilent is available.

**HP 89441V
Operator's Guide**

READ ME FIRST

The documentation for the HP 89441V VSB/QAM Signal Analyzer consists of the *HP 89441V Operator's Guide*, the analyzer's online help, and the following HP 89441A books:

- *HP 89440A/HP 89441A Getting Started Guide*
- *HP 89441A Installation and Verification Guide*
- *HP 89400-Series HP-IB Command Reference*
- *HP-IB Programmer's Guide*
- *HP 89400-Series HP-IB Quick Reference*

The analyzer's online help and the HP 89441A books contain a superset of information for the HP 89441V. Besides documenting the HP 89441V, the online help and HP 89441A books also document features and options not included in the HP 89441V. In particular, the HP 89441V does not have the source types used in chapters 3, 4, and 5 of the *Getting Started Guide*. However, the *Getting Started Guide* does contain tasks that show you how to use the analyzer's online help, make simple noise measurements, and perform general tasks. The *HP 89441V Operator's Guide* contains tasks that will help you get started making video demodulation measurements. Keep the following in mind when using the online help and HP 89441A books:

The HP 89441V does *not* include the following HP 89441A standard features:

- Analog Demodulation instrument mode
- Periodic chirp and arbitrary source types

The HP 89441V includes the following HP 89441A options:

- AYH—Digital Video Modulation Analysis (excluding selectable filtering)
- AYJ—Adaptive Equalization
- UFG—4 megabyte Extended RAM and Additional I/O

The HP 89441V can *not* be upgraded with the following HP 89441A options:

- AYA—Vector Modulation Analysis
- AYB—Waterfall and Spectrogram

HP Part No. 89441-90063
Printed in USA
Print Date: October 1997

Warranty

The information contained in this document is subject to change without notice.

Hewlett-Packard makes no warranty of any kind with regard to this material, including, but not limited to, the implied warranties or merchantability and fitness for a particular purpose.

Hewlett-Packard shall not be liable for errors contained herein or for incidental or consequential damages in connection with the furnishing, performance, or use of this material.

Safety Summary

The following general safety precautions must be observed during all phases of operation, service, and repair of this instrument. Failure to comply with these precautions or with specific warnings elsewhere in this manual violates safety standards of design, manufacture, and intended use of the instrument. Hewlett-Packard Company assumes no liability for the customer's failure to comply with these requirements. This is a Safety Class I instrument.

Ground the Instrument

To minimize shock hazard, the instrument chassis and cabinet must be connected to an electrical ground. The instrument is equipped with a three-conductor ac power cable. The power cable must either be plugged into an approved three-contact electrical outlet or used with a three-contact to two-contact adapter with the grounding wire (green) firmly connected to an electrical ground (safety ground) at the power outlet. The power jack and mating plug of the power cable meet International Electrotechnical Commission (IEC) safety standards.

Do Not Operate in an Explosive Atmosphere

Do not operate the instrument in the presence of flammable gases or fumes. Operation of any electrical instrument in such an environment constitutes a definite safety hazard.

Keep Away from Live Circuits

Operating personnel must not remove instrument covers. Component replacement and internal adjustments must be made by qualified maintenance personnel. Do not replace components with power cable connected. Under certain conditions, dangerous voltages may exist even with the power cable removed. To avoid injuries, always disconnect power and discharge circuits before touching them.

Do Not Service or Adjust Alone

Do not attempt internal service or adjustment unless another person, capable of rendering first aid and resuscitation, is present.

Do Not Substitute Parts or Modify Instrument

Because of the danger of introducing additional hazards, do not install substitute parts or perform any unauthorized modification to the instrument. Return the instrument to a Hewlett-Packard Sales and Service Office for service and repair to ensure the safety features are maintained.

Dangerous Procedure Warnings

Warnings accompany potentially dangerous procedures throughout this manual. Instructions contained in the warnings must be followed.

Cleaning

To prevent electrical shock, disconnect this product from mains before cleaning. Only use a dry cloth or one slightly dampened with water to clean external parts. DO NOT attempt to clean internally!

Safety Symbols

The following safety symbols are used throughout this manual and in the instrument. Familiarize yourself with each symbol and its meaning before operating this instrument.

General Definitions of Safety Symbols Used on Equipment or in Manuals



Instruction manual symbol. The product is marked with this symbol when it is necessary for the user to refer to the instruction manual to protect against damage to the instrument.



Indicates dangerous voltage (terminals fed from the interior by voltage exceeding 1000 volts must be so marked).



Protective ground (earth) terminal. Used to identify any terminal which is intended for connection to an external protective conductor for protection against electrical shock in case of a fault, or to the terminal of a protective ground (earth) electrode.



Low-noise or noiseless, clean ground (earth) terminal. Used for a signal common, as well as providing protection against electrical shock in case of a fault. A terminal marked with this symbol must be connected to ground in the manner described in the installation (operating) manual, and before operating the equipment.



Frame or chassis terminal. A connection to the frame (chassis) of the equipment which normally includes all exposed metal structures.



Alternating current (power line).



Direct current (power line).



Alternating or direct current (power line).

Warning

The warning sign denotes a hazard. It calls attention to a procedure, practice, condition or the like, which if not correctly performed or adhered to, could result in injury or death to personnel.

Caution

The caution sign denotes a hazard. It calls attention to an operating procedure, practice, condition or the like, which, if not correctly performed or adhered to, could result in damage to or destruction of part or all of the product or the user's data.

HP 89441V Operator's Guide

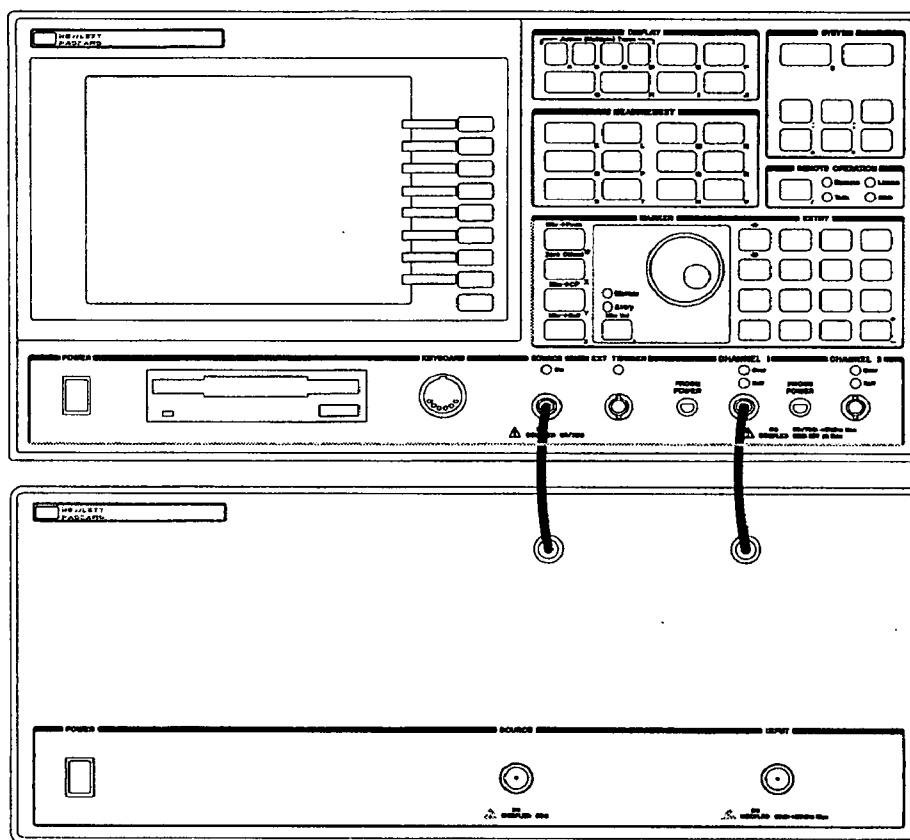

HP Part Number 89441-90061

For instruments with firmware version A.05.10

Printed in U.S.A.

Print Date: October 1997

© Hewlett-Packard Company, 1993-1997. All rights reserved.
8600 Soper Hill Road Everett, Washington 98205-1298 U.S.A.

This software and documentation is based in part on the Fourth Berkeley Software Distribution under license from The Regents of the University of California. We acknowledge the following individuals and institutions for their role in the development: The Regents of the University of California.

Portions of the TCP/IP software are copyright Phil Karn, KA9Q.

The Analyzer at a Glance

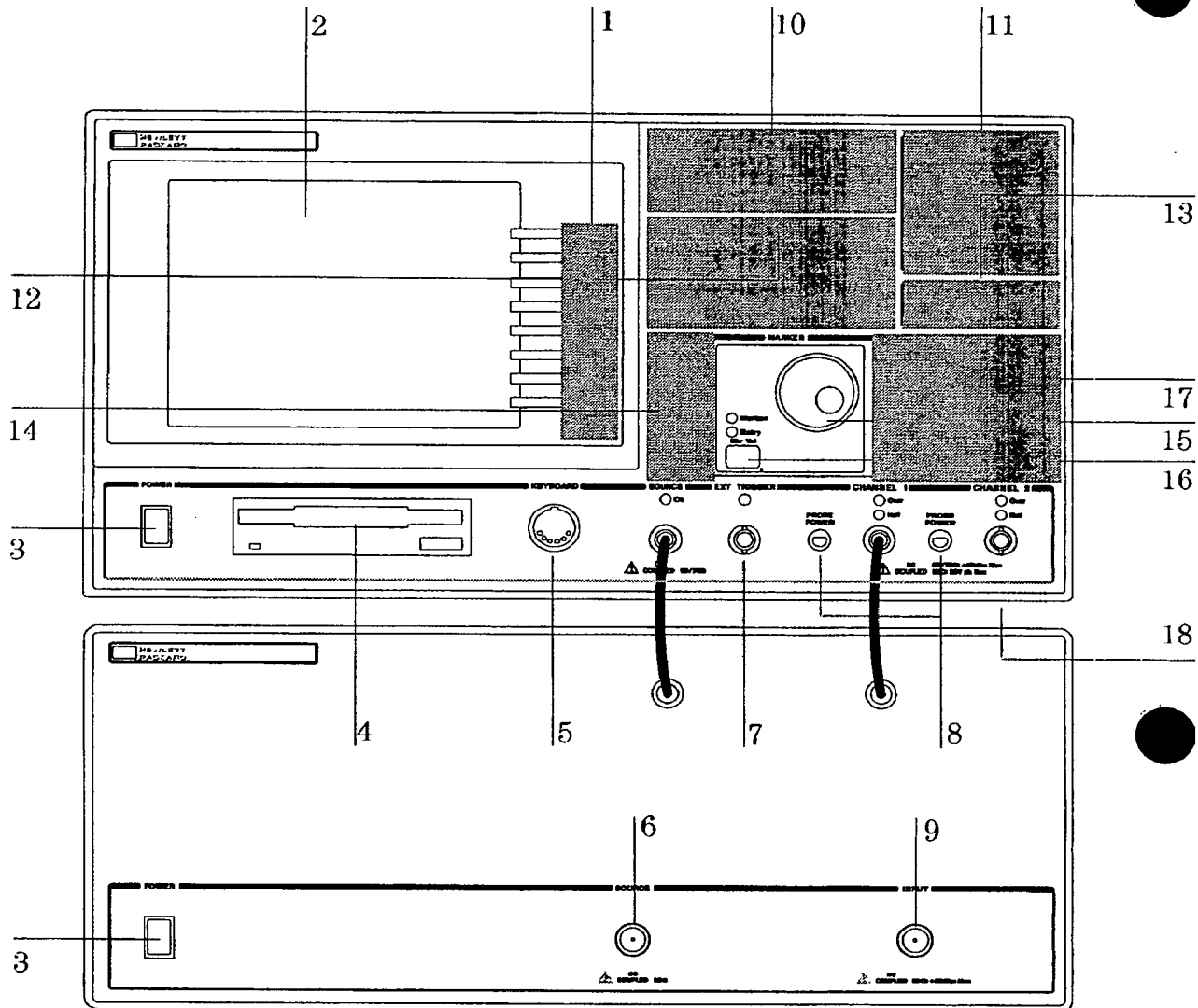

Front Panel

- 1**-A softkey's function changes as different menus are displayed. Its current function is determined by the video label to its left, on the analyzer's screen.
 - 2**-The analyzer's screen is divided into two main areas. The menu area, a narrow column at the screen's right edge, displays softkey labels. The data area, the remaining portion of the screen, displays traces and other data.
 - 3**-The POWER switch turns the analyzer on and off.
 - 4**-Use a 3.5 inch flexible disk (DS,HD) in this disk drive to save your work.
 - 5**-The KEYBOARD connector allows you to attach an optional keyboard to the analyzer. The keyboard is most useful for writing and editing HP Instrument BASIC programs.
 - 6**-The SOURCE connector routes the analyzer's source output to your DUT. If option AY8 (internal RF source) is installed, the connector is a type-N. If option AY8 is not installed, the connector is a BNC. Output impedance is selectable: 50 ohms or 75 ohms with option 1D7 (minimum loss pads).
 - 7**-The EXT TRIGGER connector lets you provide an external trigger for the analyzer.
 - 8**-The PROBE POWER connectors provides power for various HP active probes.
 - 9**-The INPUT connector routes your test signal or DUT output to the analyzer's receiver. Input impedance is selectable: 50 ohms or 75 ohms with option 1D7 (minimum loss pads).
 - 10**-Use the DISPLAY hardkeys and their menus to select and manipulate trace data and to select display options for that data.
 - 11**-Use the SYSTEM hardkeys and their menus to control various system functions (online help, plotting, presetting, and so on).
 - 12**-Use the MEASUREMENT hardkeys and their menus to control the analyzer's receiver and source, and to specify other measurement parameters.
 - 13**-The REMOTE OPERATION hardkey and LED indicators allow you to set up and monitor the activity of remote devices.
 - 14**-Use the MARKER hardkeys and their menus to control marker positioning and marker functions.
 - 15**-The knob's primary purpose is to move a marker along the trace. But you can also use it to change values during numeric entry, move a cursor during text entry, or select a hypertext link in help topics.
 - 16**-Use the Marker/Entry key to determine the knob's function. With the Marker indicator illuminated the knob moves a marker along the trace. With the Entry indicator illuminated the knob changes numeric entry values.
 - 17**-Use the ENTRY hardkeys to change the value of numeric parameters or to enter numeric characters in text strings.
 - 18**-The optional CHANNEL 2 input connector routes your test signal or DUT output to the analyzer's receiver. Input impedance is selectable: 50 ohms, 75 ohms, or 1 megohm. For ease of upgrading, the CHANNEL 2 BNC connector is installed even if option AY7 (second input channel) is not installed.
- For more details on the front panel, display the online help topic "Front Panel". See the chapter "Using Online Help" if you are not familiar with using the online help index.**

This page left intentionally blank

Options and Accessories

To determine if an option is installed, press [**System Utility**] [option setup]. Installed options are also listed on the analyzer's rear panel.

To order an option to upgrade your HP 89441V, order HP 89441U followed by the option number.

Option Description	HP 89441U Option	
Add Internal RF Source	AY8	
Add High Precision Frequency Reference	AYC	
Add Digital Video Modulation Analysis and Adaptive Equalization	AYH (Standard for HP 89441V)	
Add Adaptive Equalization	AYJ (Standard for HP 89441V)	
Add Second 10 MHz Input Channel.	AY7	
Extend Time Capture to 1 megasample	AY9	
Add 4 megabyte Extended RAM and Additional I/O	UFG (Standard for HP 89441V)	
Add Advanced LAN Support (requires option UFG)	UG7	
Add HP Instrument BASIC	1C2	
Add 50 - 75 Ohm Minimum Loss Pads	1D7	
Add PC-Style Keyboard and Cable	U.S. version	1F0
Add PC-Style Keyboard and Cable	German version	1F1
Add PC-Style Keyboard and Cable	Spanish version	1F2
Add PC-Style Keyboard and Cable	French version	1F3
Add PC-Style Keyboard and Cable	U.K. version	1F4
Add PC-Style Keyboard and Cable	Italian version	1F5
Add PC-Style Keyboard and Cable	Swedish version	1F6
Add Front Handle Kit	AX3	
Add Rack Flange Kit	AX4	
Add Flange and Handle Kit	AX5	
Add Extra Manual Set	OB1	
Add Extra Instrument BASIC Manuals	OBU	
Add Service Manual	OB3	

The accessories listed in the following table are supplied with the HP 89441V.

Supplied Accessories	Part Number
Line Power Cable	See <i>HP 89441A Installation and Verification Guide</i>
Rear Panel Lock Foot Kit	HP 5062-3999
BNC Cable - 12 inch	HP 8120-1838
2 BNC Cables - 8.5 inch	HP 8120-2682
Coax BNC(m)-to-coax BNC(m) Connector (deleted with option AY4)	HP 1250-1499
Type N-to-BNC Adapter (2 with option AY8)	HP 1250-0780
Serial Interface Interconnect Cable	HP 8120-6230
Interconnect Cable EMI Suppressor	HP 9170-1521
Standard Data Format Utilities	HP 5061-8054
<i>HP 89441V Operator's Guide</i>	(see title page in manual)
<i>HP 89440A/HP 89441A Getting Started Guide</i>	(see title page in manual)
<i>HP 89441A Installation and Verification Guide</i>	(see title page in manual)
<i>HP 89400-Series HP-IB Command Reference</i>	(see title page in manual)
<i>HP-IB Programmer's Guide</i>	(see title page in manual)
<i>HP 89400-Series HP-IB Quick Reference</i>	(see title page in manual)

The accessories listed in the following table are available for the HP 89441V.

Available Accessories	Part Number
HP 89411A 21.4 MHz Down Converter	HP 89411A
<i>HP 89400-Series Using HP Instrument BASIC</i>	HP 89441-90013
<i>HP Instrument BASIC User's Handbook</i>	HP E2083-90005
<i>Spectrum and Network Measurements</i>	HP 5960-5718
Box of ten 3.5-inch double-sided, double-density disks	HP 92192U
Active Probe	HP 41800A
Active Probe	HP 54701A
Resistor Divider Probe	HP 10020A
Differential Probe (requires HP 1142A)	HP 1141A
Probe Control and Power Module	HP 1142A
50 Ohm RF Bridge	HP 86205A
Switch/Control Unit	HP 3488A
High-Performance Switch/Control Unit	HP 3235A
HP-IB Cable - 1 meter	HP 10833A
HP-IB Cable - 2 meter	HP 10833B
HP-IB Cable - 4 meter	HP 10833C
HP-IB Cable - 0.5 meter	HP 10833D

This page left intentionally blank.

Notation Conventions

Before you use this book, it is important to understand the types of keys on the front panel of the analyzer and how they are denoted in this book.

Hardkeys Hardkeys are front-panel buttons whose functions are always the same. Hardkeys have a label printed directly on the key. In this book, they are printed like this: [Hardkey].

Softkeys Softkeys are keys whose functions change with the analyzer's current menu selection. A softkey's function is indicated by a video label to the left of the key (at the edge of the analyzer's screen). In this book, softkeys are printed like this: [softkey].

Toggle Softkeys Some softkeys toggle through multiple settings for a parameter. Toggle softkeys have a word highlighted (of a different color) in their label. Repeated presses of a toggle softkey changes which word is highlighted with each press of the softkey. In this book, toggle softkey presses are shown with the requested toggle state in bold type as follows:

"Press [key name **on**]" means "press the softkey [key name] until the selection **on** is active."

Shift Functions In addition to their normal labels, keys with blue lettering also have a shift function. This is similar to shift keys on a pocket calculator or the shift function on a typewriter or computer keyboard. Using a shift function is a two-step process. First, press the blue [Shift] key (at this point, the message "shift" appears on the display). Then press the key with the shift function you want to enable. Shift function are printed as two key presses, like this:

[Shift] [Shift Function]

Numeric Entries Numeric values may be entered by using the numeric keys in the lower right hand ENTRY area of the analyzer front panel. In this book values which are to be entered from these keys are indicated only as numerals in the text, like this: Press 50, [enter]

Ghosted Softkeys A softkey label may be shown in the menu when it is inactive. This occurs when a softkey function is not appropriate for a particular measurement or not available with the current analyzer configuration. To show that a softkey function is not available, the analyzer "ghosts" the inactive softkey label. A ghosted softkey appears less bright than a normal softkey. Settings/values may be changed while they are inactive. If this occurs, the new settings are effective when the configuration changes such that the softkey function becomes active.

This page left intentionally blank.

In This Book

This book, *HP 89441V Operator's Guide*, is designed to advance your knowledge of the HP 89441V VSB/QAM Signal Analyzer. You should already feel somewhat comfortable with this analyzer, either through previous use or through performing the tasks in chapters 1, 2, and 6 in the *HP 89440A/HP 89441A Getting Started Guide*. The HP 89441V does not have the source types used in chapters 3, 4, and 5 of the *Getting Started Guide*. This book consists of both measurement tasks and concepts.

Measurement tasks

Measurement tasks provide step-by-step examples of how to perform specific tasks with your HP 89441V VSB/QAM Signal Analyzer. These tasks may be similar to measurements you wish to make and you can modify them to meet your own needs. Even if these tasks are not specifically related to your measurement needs, you may find it helpful to perform the tasks anyway—they only take a few minutes each—since they will help you become familiar with many of your analyzer's features.

Concepts

The concepts section provides you with a conceptual overview of the HP 89441V and its essential features. This section assumes that you are already familiar with basic measurement concepts and is helpful in understanding the similarities and differences between the HP 89400 series analyzers and other analyzers you may have used. The concepts are also essential if you want to make the best use of the analyzer's features.

To Learn More About the HP 89441V

You may need to use other books in the HP 89400 series manual set. See the "Documentation Roadmap" at the end of this book to learn what each book contains.

This page left intentionally blank.

Table of Contents

1 Using Video Demodulation

- To prepare a VSB measurement 1-2
- To determine the center frequency for a VSB signal 1-4
- To demodulate a VSB signal 1-6
- To measure the peak-to-average power ratio 1-8
- To prepare a QAM or DVB QAM measurement 1-10
- To demodulate a QAM or DVB QAM signal 1-12
- To select measurement and display features 1-14
- To set up sync search (QAM only) 1-16
- To select and create stored sync patterns (QAM only) 1-18
- To demodulate a two-channel I/Q signal 1-19

2 Using Adaptive Equalization

- To load the multi-path signal from the Signals Disk 2-2
- To demodulate the multi-path signal 2-3
- To apply adaptive equalization 2-5
- To measure signal paths 2-8
- To learn more about equalization 2-10

3 Using Band-Power Markers

- To measure band power with improved dynamic range 3-2

4 Using the LAN

- To determine if you have option UG7 4-2
- To connect the analyzer to a network 4-3
- To set the analyzer's network address 4-4
- To activate the analyzer's network interface 4-5
- To send HP-IB commands to the analyzer 4-6
- To select the remote X-Windows server 4-7
- To initiate remote X-Windows operation 4-8
- To use the remote X-Windows display 4-9
- To transfer files via the network 4-10

5 Using the HP 89411A Downconverter

- Connection and setup details for the HP 89411A 5-4

6 Choosing an Instrument Mode

- Why Use Scalar Mode? 6-2
- Why Use Vector Mode? 6-4
- Why Use Video Demodulation Mode? 6-6
- The Advantage of Using Multiple Modes 6-7
- Instrument Mode? Measurement Data? Data Format? 6-8
- Unique Capabilities of the Instrument Modes 6-9

7 What Makes this Analyzer Different?

- Time Domain and Frequency Domain Measurements 7-2
- What are the Different Types of Spectrum Analyzers? 7-4
- The Difference 7-8

8 Fundamental Measurement Interactions

- Measurement Resolution and Measurement Speed 8-2
- Windowing 8-6
- Enhancing the Measurement Speed 8-8
- Special Considerations in Scalar Mode 8-10
- Special Considerations in Vector Mode 8-14



9 Gating Concepts

What is Time Gating? 9-2

How Does it Work? 9-4

Important Concepts 9-5

Parameter Interactions 9-6

10 Video Demodulation Concepts

Overview 10-2

Measurement Flow 10-3

Measurement management 10-7

Parameter interactions 10-11

Special considerations for sync search 10-15

Special considerations for pulsed signals 10-16

Filtering 10-17

Index

Declaration of Conformity

Need Assistance?

Documentation Roadmap

HP 89441V Technical Specifications



1

Using Video Demodulation

This chapter shows you how to use digital video demodulation to demodulate and view digitally-modulated video signals. You may perform the tasks in this chapter using signals from the Signals Disk, or you may use these tasks as a model for demodulating your own signals.

To prepare a VSB measurement

This task shows you how to load and view the 8 VSB signal located on the Signals Disk. If you have your own 8 VSB signal, use the steps below and enter the demodulation parameters for your signal.

1 Initialize the analyzer:

Press **[Preset]**.
Press **[Instrument Mode]**, [receiver], [RF section (0-10 MHz)].
Press **[Instrument Mode]**, [Vector].
Press **[System Utility]**, [memory usage], [configure meas memory].
Press [max freq pts], 1601 [enter].
Press [max time pts], 4096 [enter].

2 If your analyzer has the optional second input channel installed, turn it off:

Press **[Input]**, [channel 2], [ch2 state off].

3 Supply an 8 VSB signal to the INPUT or perform the following steps to load an 8 VSB signal from the Signals Disk into the analyzer's time-capture RAM:

Insert the Signals Disk into the internal disk drive.

Press **[Save/Recall]**, [default disk], [internal disk].

Press **[Return]**, [catalog on].

Rotate the knob to highlight 8VSB.CAP

Press [recall more], [recall capture buffer], [enter].

4 Turn on averaging:

Press **[Average]**, [average on].

5 Measure and scale the displayed trace:

Press **[Meas Restart]**, **[Auto Scale]**.

When you measure time-capture data, the analyzer automatically sets its frequency span and center frequency to that used to capture the data. Therefore, you did not need to set these parameters in the above steps.

If you are not measuring time-capture data, you must set the center frequency, frequency span, and range. If these parameters are incorrect, the analyzer may not lock to your carrier, measurement speed may be reduced, or you may see excessive errors in the demodulated results. For details about setting these parameters, see "Carrier locking", "Input Range", and "Span considerations" in the *Video Demodulation Concepts* chapter. The next task, "To determine the center frequency for a VSB signal", shows you how to determine the correct center frequency.

VSB measurements typically require a large portion of measurement memory. Therefore, it is a good idea to choose the maximum value (4096) for [max time points] (see step 1). For details about [max time points], see online help (press [Help], then press [max time points]).

Note

Before demodulating a VSB signal, view the signal in Vector mode to verify that the pilot is on the left (low) side of the spectrum. If it isn't, you must configure the analyzer to demodulate a high-side pilot. For further details, see "To demodulate a VSB signal."

To demodulate VSB signals, the pilot must be on the left (low) side of the spectrum. If it isn't, you must configure the analyzer to demodulate a high-side pilot, as shown in "To demodulate a VSB signal."

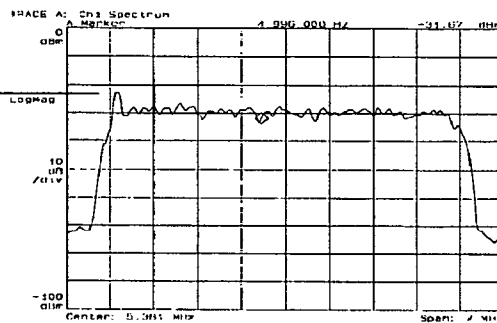

Spectrum of an 8 VSB signal

To determine the center frequency for a VSB signal

Choosing the correct center frequency is important for all digital video demodulation measurements. This task shows you how to determine the correct center frequency for VSB measurements. To learn how to determine the correct center frequency for QAM measurements, see the "Video Demodulation Concepts" chapter. Note that you must supply an 8 VSB signal to perform this task. You cannot use the time-capture signal from the signals disk because this task uses the analyzer's frequency counter, which cannot be used on time capture data.

1 Initialize the analyzer:

Press **[Preset]**.

Press **[Instrument Mode]**, [receiver], [RF section (0-10 MHz)].

Press **[Instrument Mode]**, [Vector].

2 Increase the display resolution:

Press **[ResBw/Window]**.

Press [num freq pts], 1601 [enter].

Press [rbw mode **arb**].

Press [rbw] and press the down-arrow key to select the smallest resolution bandwidth.

3 Position the marker on the pilot:

Press **[Shift]**, **[Marker]**.

4 Turn on the frequency counter:

Press **[Marker Function]**, [freq counter on].

5 Compute the ideal center frequency:

$$\text{Center Frequency (LOW SIDE PILOT)} = \frac{\text{Symbol Rate}}{4} + (\text{Pilot Frequency})$$

$$\text{Center Frequency (HIGH SIDE PILOT)} = (\text{Pilot Frequency}) - \frac{\text{Symbol Rate}}{4}$$

In this example, the symbol rate is 10.762 MHz, the frequency counter shows the pilot frequency at 3.308894876 MHz, and the pilot is on the low side of the spectrum. Using the formula for low-side pilot, the ideal center frequency is 5.999394876 MHz. A center frequency of 6 MHz is close enough to ensure carrier lock.

6 Set the center frequency to the computed value:

Press [Frequency], [center], 6 [MHz].

Note

If your pilot is on the high (right) side of the spectrum, you must configure the analyzer to demodulate a high-side pilot. For further details, see the next task: "To demodulate a VSB signal."

In this example, the pilot is on the low (left) side of the spectrum.

Frequency counter readout. In this example, this is the frequency of the pilot signal.

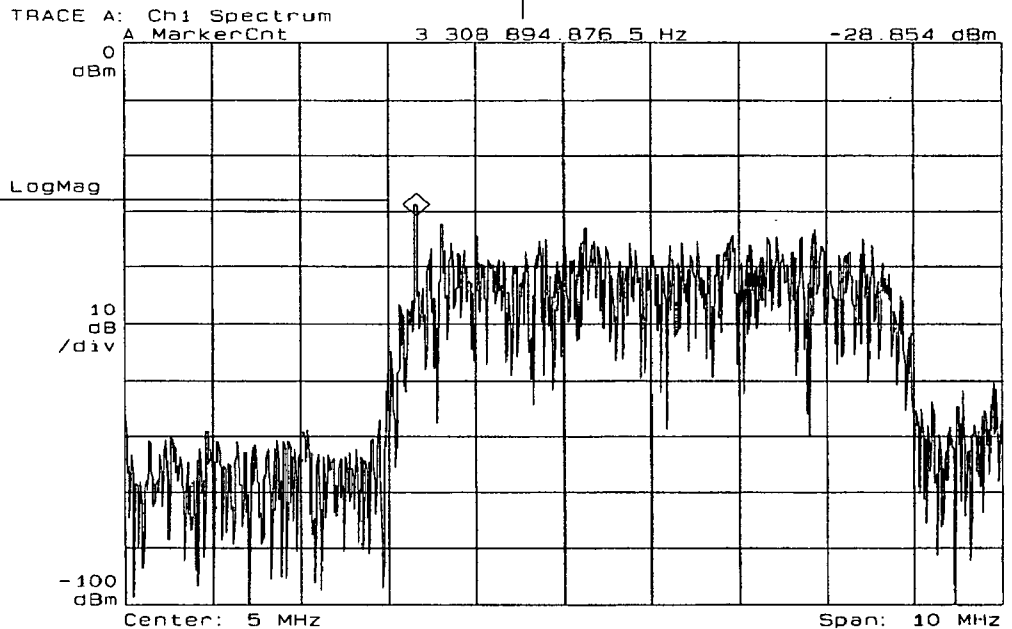

8 VSB Signal With Low-Side Pilot

To demodulate a VSB signal

This task shows you how to demodulate a VSB signal. The task uses the 8 VSB time-capture signal that you loaded into the analyzer in “To prepare a VSB measurement”.

- 1** Prepare the analyzer for a VSB measurement as shown in “To prepare a VSB measurement”.
- 2** Turn averaging off and restart the measurement:
Press **[Average]**, [average off].
Press **[Meas Restart]**.
- 3** Demodulate the signal:
Press **[Instrument Mode]**, [Video Demodulation].
- 4** Select the correct demodulation parameters for the 8 VSB signal (if you are not using the signal provided on the Signals Disk, enter the parameters for your signal) :
Press [demodulation setup].
Press [demod format], [VSB 8], [Return].
Press [symbol rate], 10.762 [MHz].
Press [result length], 800 [sym].
Press [filter alpha], .1152 [enter].
Press **[Time]**, [points/symbol], 5 [enter].
Press [pulse search off], [sync search off].
- 5** If the pilot is on the left (low) side of the spectrum, configure the analyzer to demodulate a low-side pilot (if you are using the signal provided on the Signals Disk, the pilot is on the left side of the spectrum):
Press **[Instrument Mode]**, [demodulation setup], [demod format], [freq spectrum normal].
- 6** If the pilot is on the right (high) side of the spectrum, configure the analyzer to demodulate a high-side pilot:
Press **[Instrument Mode]**, [demodulation setup], [demod format], [freq spectrum mirror].

To learn what [freq spectrum mirror] does, see online help (press **[Help]**, then press [freq spectrum]).

7 View the constellation and eye diagram:

Press **[Display]**, [2 grids].
 Press **[A]**, **[Measurement Data]**, [IQ measured **time**].
 Press **[Data Format]**, [polar (IQ) **constellation**].
 Press **[B]**, **[Measurement Data]**, [IQ measured **time**].
 Press **[Data Format]**, [eye diagram **I**].

With VSB signals, symbol locations (detection decision points) are derived from the real portion (I) of the demodulated data. This is evident in the constellation diagram where you see symbols aligned vertically in 8 locations (16 locations for 16 VSB) along the I-axis. The vertical lines in the constellation diagram indicate ideal symbol locations.

Hint

Displayed data must contain real data to see symbol locations for VSB signals. For example, if you press **[Data Format]** and select the imaginary part of the data or the Q eye-diagram, you won't see symbol information.

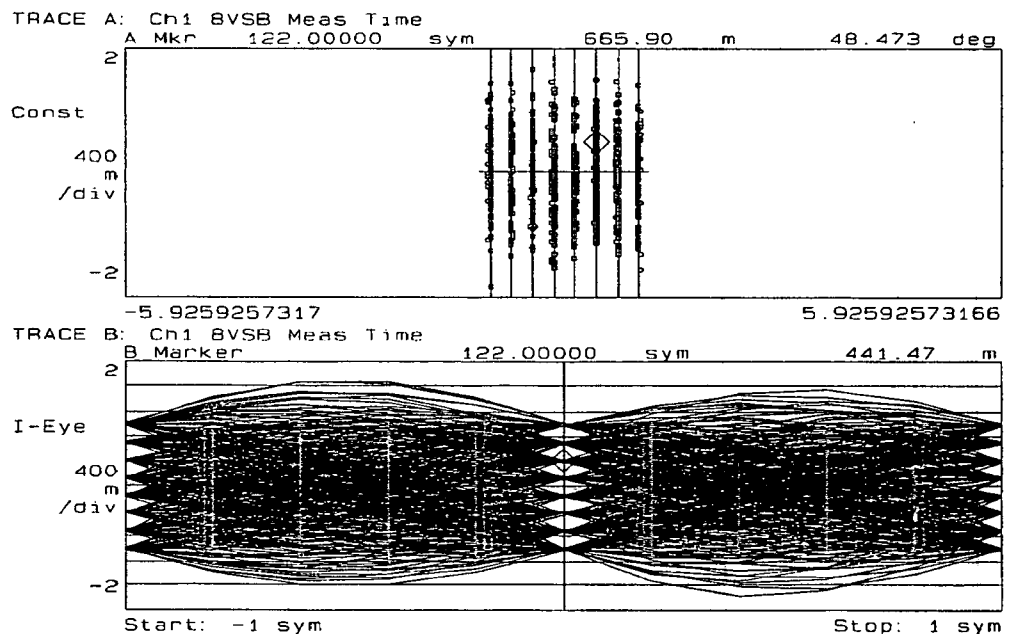

Constellation and eye diagram for 8 VSB signal

To measure the peak-to-average power ratio

This task shows you how to measure the peak-to-average power ratio of a digitally modulated signal. The task uses the 8 VSB time-capture signal that you loaded into the analyzer in "To prepare a VSB measurement".

- 1** Prepare the analyzer for a VSB measurement as shown in "To prepare a VSB Measurement".

- 2** View the time waveform:

Press **[A]**, **[Measurement Data]**, [main time] or [main time ch1].
Press **[Data Format]**, [magnitude log(dB)].

- 3** Enable time domain calibrations:

Press **[System Utility]**, [time domain cal on].

In vector mode, calibrations are normally applied only to the spectrum data. The peak-to-average power measurements are performed on the time data, so the data must be calibrated for greatest accuracy.

- 4** If you are measuring the 8 VSB time-capture signal, disable averaging and overlap processing of the time capture buffer:

Press **[Average]**, [average off].
Press **[Time]**, [overlap], [ovlp: avg off], 0 [%].

- 5** Enable peak-to-average measurements on Trace A

Press **[Marker Function]**, [peak/average statistics], [statistics on].

- 6** Measure the peak-to-average power ratio:

Press **[Meas Restart]**, **[Auto Scale]**.

The ratio of the peak-to-average power is displayed near the bottom of the trace. The value is related to the peak percent specified in the peak/average statistics menu. The peak percent value may be adjusted after the measurement has been completed.

7 Adjust [peak percent] to set the probability that the instantaneous power will be below a level that is 6 dB above the signal's average power:

Press [Marker Function], [peak/average statistics].

Press [peak percent], [Return].

Press [Marker/Entry] to illuminate the Entry LED.

While observing the Peak/Avg ratio on the trace, adjust the Marker knob until the ratio is near 6 dB.

The peak percent key should read near 99.78%. This implies that 99.78% of the time, the signal power is below 6 dB above average, or 0.22% of the time, the signal power exceeds a level that is 6 dB above the average power.

8 Determine the average signal power in dB:

Press [average power].

Press [Ref Lvl/Scale], [X&Y units setup], [Y units], [dBm].

The result should be near -11.7 dBm.

9 Determine the average signal power in Watts:

Press [Data format], [magnitude linear].

Press [Ref Lvl/Scale], [X&Y units setup], [Y units], [W].

Press [Auto Scale].

The result should be near 66.8 uW.

10 View the peak-to-average ratio in linear units:

Press [Marker Function], [peak/average statistics], [peak/average].

The power ratio was expressed in dB. When the display data format was changed to linear magnitude, the ratio also changed from a log to linear format. So, instead of 6 dB, the ratio is now reported as 4 (i.e., a peak-to-average power ratio of four-to-one).

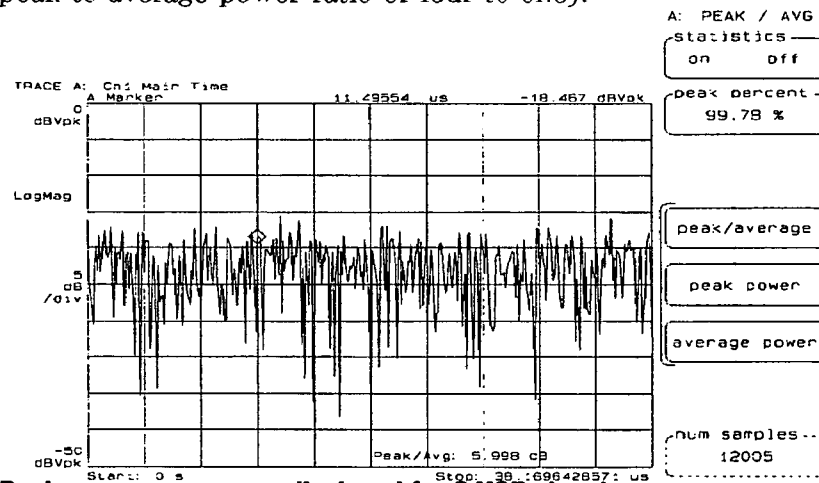

Peak-to-average power displayed for 8 VSB signal

To prepare a QAM or DVB QAM measurement

This task shows you one way to set up a QAM or DVB QAM measurement. The task uses the RF section (0-10 MHz) receiver and a 32 QAM signal from the signals disk. Several other tasks in this chapter use this setup to teach you how to use video demodulation.

1 Initialize the analyzer:

Press **[Preset]**.

Press **[Instrument Mode]**, [receiver], [RF section (0-10 MHz)].

Press **[Instrument Mode]**, [Vector].

Press **[System Utility]**, [memory usage], [configure meas memory].

Press [max time pts], 4096 [enter].

2 If your analyzer has the optional second input channel installed, turn it off:

Press **[Input]**, [channel 2], [ch2 state off].

3 Supply a 32 QAM signal to the INPUT or perform the following steps to load a 32 QAM signal from the Signals Disk into the analyzer's time-capture RAM:

Insert the Signals Disk into the internal disk drive.

Press **[Save/Recall]**, [default disk], [internal disk].

Press [Return], [catalog on].

Rotate the knob to highlight 32QAM.CAP

Press [recall more], [recall capture buffer], [enter].

Press [catalog off].

When you measure time-capture data, the analyzer automatically sets its frequency span and center frequency to that used to capture the data. Therefore, you did not need to set these parameters in the above steps.

If you are not measuring time-capture data, you must set the center frequency and frequency span. The center frequency tunes the analyzer to the carrier frequency. To obtain reliable carrier lock, the center frequency must be close to the carrier frequency. For details, see "Carrier Locking" in the *Video Demodulation Concepts* chapter.

Selecting the correct frequency span is also important when using video demodulation. The span must be wide enough to include all signal components, and yet not too wide, or the measurement may be affected by excessive noise and slower speed. For details, see "Parameter Interactions" in the *Video Demodulation Concepts* chapter.

4 Measure and scale the displayed trace:

Press [Meas Restart], [Auto Scale].

This task sets [max time pts] to its maximum value (4096), which allocates the maximum amount of measurement memory for digital video demodulation. This lets you choose larger result lengths, search lengths, and points-per-symbol. For additional details about allocating memory for digital video demodulation, see "Parameter Interactions" in the *Video Demodulation Concepts* chapter and see online help for [max time points], (press [Help], then press [max time points]).

QAM and DVB QAM measurements treat I/Q origin offset differently. QAM measurements remove I/Q origin offset, DVB QAM measurements *do not* remove I/Q origin offset. Both demodulation formats report I/Q origin offset (in the symbol table).

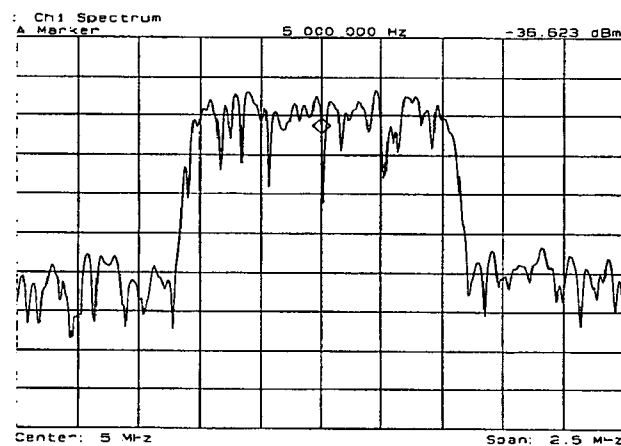

The spectrum of a 32 DVB QAM signal before demodulation.

To demodulate a QAM or DVB QAM signal

This task shows you how to demodulate the 32 DVB QAM signal generated in "To prepare a QAM or DVB QAM measurement". Prior to demodulating your own video signal, you must select the correct center frequency, frequency span, and range as shown in that task. You use the same procedure to demodulate both QAM and DVB QAM signals.

- 1** Prepare the analyzer for a DVB QAM measurement as shown in the previous task.
- 2** Demodulate the signal:
Press **[Instrument Mode]**, **[Video Demodulation]**.
- 3** Select the correct demodulation parameters for the 32 DVB QAM signal (if you are not using the signal provided on the Signals Disk, enter the parameters for your signal) :
Press **[demodulation setup]**.
Press **[demod format]**, **[DVB QAM 32]**, **[Return]**.
Press **[symbol rate]**, **1 [MHz]**.
Press **[result length]**, **400 [sym]**.
Press **[filter alpha]**, **.15 [enter]**.
Press **[Time]**, **[points/symbol]**, **5 [enter]**.
Press **[pulse search off]**, **[sync search off]** .
- 4** View the created signal versus the reference:
Press **[Display]**, **[2 grids]**.
Press **[A]**, **[Measurement Data]**, **[IQ measured time]**.
Press **[B]**, **[Measurement Data]**, **[IQ reference time]**.
Press **[Shift]**, **[A]** to activate both traces.
Press **[Data Format]**, **[polar (IQ) vector]**.
Press **[more format setup]**, **[symbol dots]** (if **[symbol dots]** is already selected, you still must press this key to force both traces to display symbols as dots).
- 5** Scale both traces:
Press **[Auto Scale]**.
Press **[Meas Restart]**.

Hint

You use [demodulation setup] to set demodulation parameters, you use [Measurement Data] to select the measurement calculation used on demodulated data, and you use [Data Format] to select a display format (trace coordinates). To learn more about these keys and the choices under them, see online help. Online help contains detailed descriptions for all keys (press [Help], then press the desired key). The next task uses [Measurement Data] and [Data Format] to display a constellation diagram and the error-vector trace.

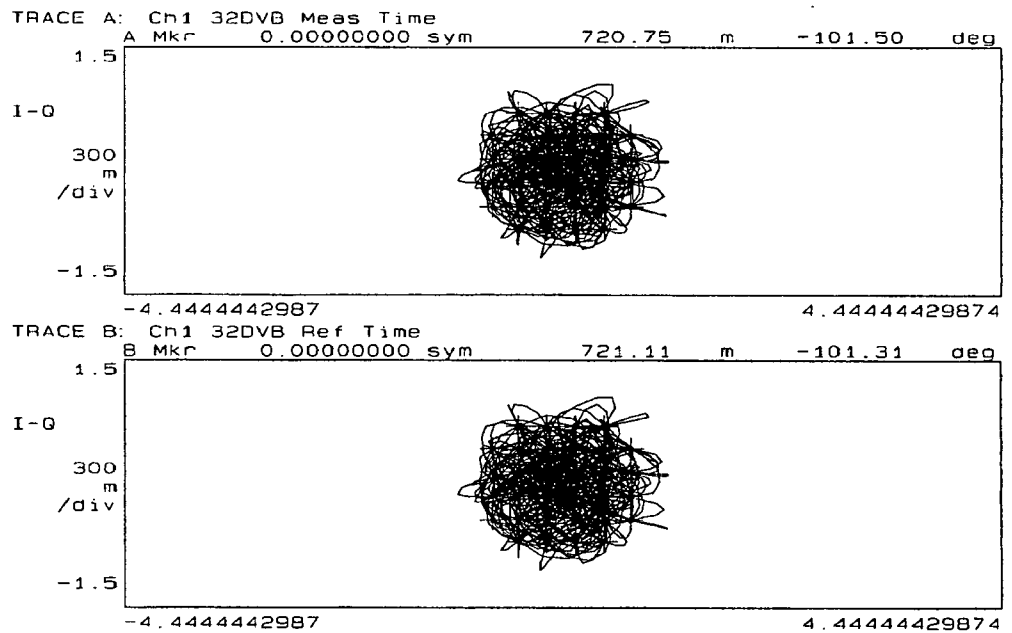

Two time displays of a demodulated signal: IQ measured versus IQ Reference

To select measurement and display features

You can display demodulated data in many different formats. This task uses the demodulated 32 DVB QAM signal from the previous task to show you just a few ways of viewing demodulated data.

1 Select multiple display grids:

Press **[Display]**, **[4 grids quad]**.

2 Change the data format for trace A:

Press **[A]**, **[Data Format]**, **[polar IQ constellation]**.

3 Change the measurement data for trace B:

Press **[B]**, **[Measurement Data]**, **[error vector time]**.

4 Scale traces A, B, and C:

Press **[Shift]**, **[A]**, **[Shift]**, **[C]** to activate traces A, B, and C.

Press **[Auto Scale]**.

By default, selecting 4 grids displays the current trace in trace A, the error-vector trace in trace B, the eye diagram in trace C, and the symbol table in trace D. Thus you can view demodulated data in four different ways at the same time.

You can change the **[Measurement Data]** and **[Data Format]** for any trace. Simply activate the trace (for example, press **[A]** to activate trace A), then select the desired measurement data and data format.

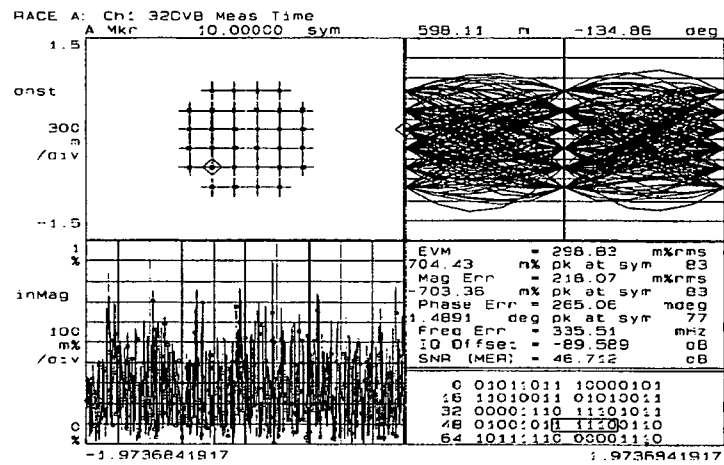

Each grid shows a different measurement type with an appropriate data format.

To set up sync search (QAM only)

In this task you learn how to synchronize your measurement by using a specific bit pattern within the chain of bits. This task uses the demodulated 32 DVB QAM signal from the previous task to show you how to define sync words and set an offset. Note that you cannot use sync search with VSB measurements.

1 Select two displays and format them:

Press **[A]**, **[Data Format]**, [magnitude **log(dB)**].

Press **[Display]**, [2 grids]

Press **[0]**.

2 Select the search length for this particular signal:

Press **[Time]**, [search length], 1000 [sym].

3 Enter a sync bit pattern:

Press [sync setup], [pattern], [clear entry], 0000011111 [enter].

4 Select an offset:

Press [offset], 6 [sym].

5 Turn on sync search:

Press [Return], [sync search **on**].

6 Disable averaging and overlap processing of the time capture buffer:

Press **[Average]**, [average **off**].

Press **[Time]**, [overlap], [ovlp: avg off], 0 [%].

The search length must be longer than the combination of result length, sync pattern, and offset. The sync pattern may include up to 32 symbols. The offset may be positive or negative. See the online help topics for more information on these keys.

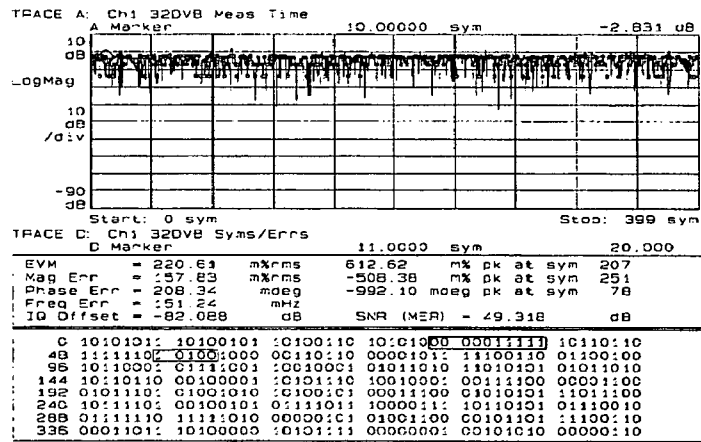

The sync word is highlighted when sync search is completed successfully

To select and create stored sync patterns (QAM only)

When using sync search you can enter a sync bit pattern as in the previous task, or you can load up to six of your own sync patterns into softkeys F3 through F8, and then use the softkeys to select a sync bit pattern. This task uses the results of the previous task.

1 Insert the Signals Disk into the analyzer's disk drive.

2 Load an example of user-defined sync patterns:

Press [Save/Recall], [catalog on].
 Scroll to highlight SYNC_KEY.TXT
 Press [recall more], [recall sync/state defs], [enter].

3 Choose one of the user-defined sync patterns:

Press [Time], [sync setup], [offset], 15 [sym], [user sync patterns].
 Press one of the six user-defined softkeys to change sync patterns.

If you select Sync 3 or Sync 4, you see what happens if the analyzer cannot find the sync pattern. The analyzer demodulates the signal but displays the message "SYNC NOT FOUND." When this happens, the result is positioned at the start of data collection. In this case, the sync is not found because the combination of offset and sync word place the result length beyond the pulse. The other four sync words show the result length on the leading edge, trailing edge, or center of the pulse.

You may create your own sync bit pattern definitions for the softkeys. See the file "STAT_DEF" on the Signals Disk. The file may be viewed and edited with any ASCII editor and the results may be saved on a disk. If you have IBASIC installed, you may use it as an editor. You may view the files "SYNC_KEY.TXT" and "STATES.TXT" to see a sync pattern and a state definition which were created by using IBASIC to modify portions of the "STAT_DEF" file.

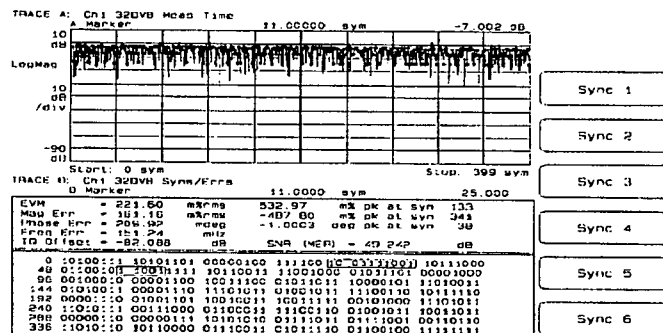

Up to 6 sync patterns may be loaded into softkeys

To demodulate a two-channel I/Q signal

Note

This measurement can only be performed with a 2-channel analyzer—you must have option AY7 (option AY7 adds a second input channel).

If you have separate baseband I and Q signals available for your measurement, you may demodulate them directly if you have a two-channel analyzer. This type of demodulation preserves the original transmitted relationship between the I and Q signals.

- 1** Apply real I and Q signals to Channel 1 and Channel 2 respectively. Be sure to use the inputs on the upper (IF) section of the analyzer.
- 2** Select the special baseband receiver mode:
Press [Instrument Mode], [receiver], [IF section (ch1 + j*ch2)].
- 3** Adjust the frequency span to encompass the signal with a span of at least 78 kHz.
- 4** Make sure that time domain calibration is on under the [System Utility] key.
- 5** Select identical parameters for both channels under the [Range] key.
- 6** Select identical parameters for both channels under the [Input] key.
- 7** Select identical parameters for both channels under the [Trigger] key.
- 8** Proceed with digital demodulation as shown previously.

For more information on this type of measurement see online help for the [IF section (ch1 + j*ch2)] key.

2

Using Adaptive Equalization

This chapter shows you how to use Adaptive Equalization. Adaptive equalization removes linear errors from modulated signals by dynamically creating and applying a compensating filter.

To load the multi-path signal from the Signals Disk

This task shows you how to load a 16-QAM, multi-path, time-capture signal from the Signals Disk. Other tasks in this section use this signal to teach you how to use adaptive equalization.

1 Initialize the analyzer and select the Video Demodulation instrument mode:

Press **[Instrument Mode]**, [receiver], [IF section (0-10 MHz)].

Press **[Preset]**.

Press **[Instrument Mode]**, [Video Demodulation].

2 If your analyzer has the optional, second input-channel installed, turn it off:

Press **[Input]**, [channel 2], [ch2 state off].

3 Load the time-capture data into the capture buffer:

Insert the Signals Disk in the analyzer's disk drive.

Press **[Save/Recall]**, [default disk], [internal disk].

Press **[Return]**, [catalog on].

Rotate the knob until the file EQSIGNAL.DAT is highlighted.

Press [recall more], [recall capture buffer], [enter].

Using time-captured data causes the analyzer to automatically measure from the capture-buffer instead of the input channel and sets the center frequency, span, and resolution bandwidth to those used when the data was captured. In a typical equalization measurement you would set these parameters instead of loading captured data.

To demodulate the multi-path signal

This task shows you how to demodulate the multi-path signal that you loaded in the previous task.

- 1** Load the multi-path signal as instructed in the previous task.
- 2** Set demodulation parameters for this signal:
 - Press **[Instrument Mode]**, [demodulation setup].
 - Press [symbol rate], 5 [MHz].
 - Press [filter alpha], 0.15 [enter].
 - Press [result length], 500 [sym].
 - Press [demod format], [QAM 16], [Return].
 - Press **[Time]**, [points/symbol], 1 [enter].
- 3** Configure different displays for the demodulated data:
 - Press **[Display]**, [4 grids **quad**].
 - Press **[A]**, [**Measurement Data**], [more choices], [channel frequency resp].
 - Press **[B]**, [equalizer impulse resp], [**Data Format**], [magnitude **log(dB)**].
 - Press **[C]**, [**Measurement Data**], [symbol table/error summary]
 - Press **[D]**, [**Measurement Data**], [IQ measured **time**],
 - Press [**Data Format**], [polar (IQ) **constellation**], [more format setup], [symbol **dots**].
- 4** Start the measurement:
 - Press **[Meas Restart]**.

Using Adaptive Equalization

Traces A and B display the frequency response and the impulse response of the equalization filter. You can view these displays even when you are not using the equalization filter. In this example equalization is turned off, therefore the equalization filter does not change and these displays remain constant.

Traces C and D display the symbol table and constellation diagram for the multi-path signal. The signal contains a significant amount of distortion which makes it difficult to demodulate. The next task uses equalization to compensate for distortion in the signal which significantly improves these displays.

By default, the equalization filter is defined to have a unit impulse response which yields a flat frequency response.

In this example, traces A and B show the default frequency response and impulse response of the equalization filter. By default, the equalization filter has a unit impulse response.

This signal is difficult to demodulate due to linear distortion. The next task uses equalization to compensate for the linear distortion.

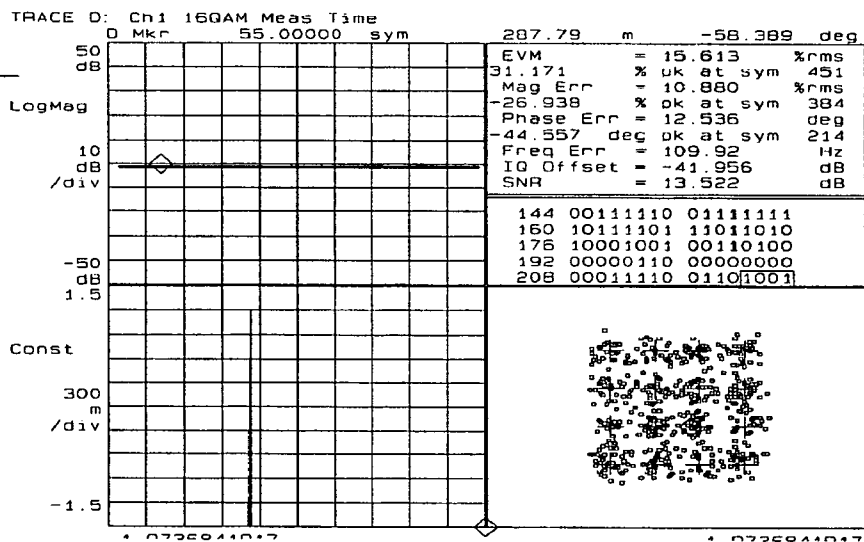

Demodulated signal and equalization filter displays

To apply adaptive equalization

This task shows you how to apply adaptive equalization to the multi-path signal that you demodulated in the previous task.

- 1 Perform the previous task.**
- 2 Display the equalization-filter menu:**
Press **[Instrument Mode]**, **[demodulation setup]**, **[equalizer]**.
- 3 Set equalization parameters for this measurement:**
Press **[eq filter len]**, **41 [sym]**.
Press **[convergence]**, then press the up or down arrow key until convergence is $2e-06$.
- 4 Configure the equalization filter to update with each measurement:**
Press **[eq adapt run]**.
- 5 Reset the equalization filter:**
Press **[eq reset]**.
- 6 Enable the equalization filter:**
Press **[eq filter on]**.
- 7 Restart the measurement:**
Press **[Meas Restart]**.
- 8 Autoscale traces A and B (the frequency response and impulse response of the equalization filter) as the analyzer shapes the equalization-filter.**
Press **[A]**
Press **[Shift]**, **[B]**.
Press **[Auto Scale]**.

Using Adaptive Equalization

This example lets you watch as the analyzer shapes the equalization filter. The analyzer estimates new filter coefficients with each measurement, and then uses the new coefficients to adapt the filter for the next measurement.

By default, the equalization filter has a unit impulse response when the analyzer is first turned on, if you press **[Preset]** or `[eq reset]`, or if you change instrument modes or `[points/symbol]`. Aside from these conditions, the analyzer uses the last computed coefficients when you enable equalization. For example, if you used equalization in a previous measurement, the analyzer uses the coefficients from the previous measurement unless you press **[Preset]** or `[eq reset]`, or change instrument modes or `[points/symbol]`. Therefore, it is good practice to press `[eq reset]` to reset the filter coefficients before you start a measurement.

The `[convergence]` determines how quickly the old and new filter-coefficients converge. Larger values converge faster. Values that are too large can cause the adaptation algorithm to become unstable or fluctuate from stable to unstable. Filter length, points-per-symbol, modulation format, and result length interact to determine the best value for convergence. Good results are normally achieved using values between 10^{-7} and 10^{-6} .

HINT

At the start of your measurement, set the convergence high to quickly shape the filter. Then decrease the convergence to fine-tune the filter to the optimum shape.

The equalization filter length (`[eq filter len]`) affects the number of taps in the equalization filter. For multi-path environments, longer filter lengths are needed to estimate good filter coefficients.

The following parameters affect measurement speed when using adaptive equalization.

- `[result length]`
- `[eq filter len]`
- `[points/symbol]`

For additional details, see online help for the `[eq filter on/off]` softkey.

In this example, trace A shows the frequency response and trace B shows the impulse response of the equalization filter. With [eq adapt run] selected, the traces change with each measurement as the analyzer updates the filter coefficients.

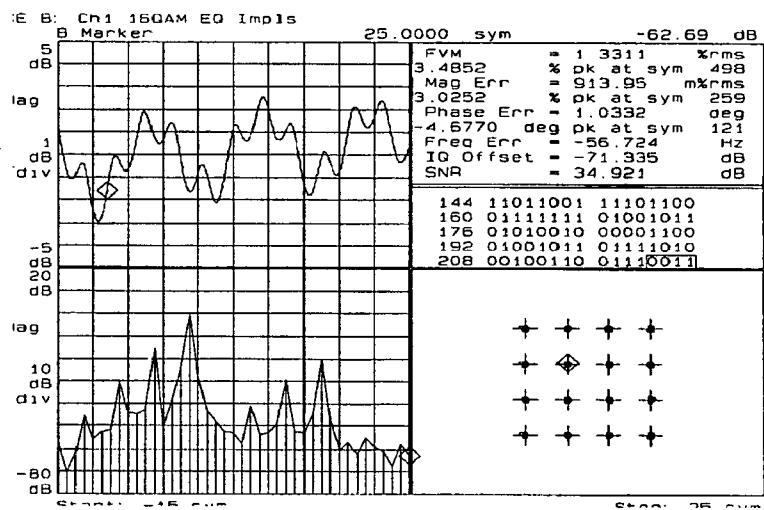

Applying equalization to the measurement

To measure signal paths

This task shows you how to use the equalization filter's impulse response to identify and measure paths in a multi-path signal. This task uses the multi-path signal on the Signals Disk and is a continuation of the previous task.

- 1** Perform the previous task.
- 2** Configure the display to show the impulse response of the equalization filter in a single grid:
Press **[B]**, **[Display]**, [single grid].
- 3** Change the x-axis units to seconds from the default unit of symbols:
Press **[Ref Lvl/Scale]**, [X & Y units setup], [X units], [s].
- 4** Display bars at the symbol locations:
Press **[Data Format]**, [more format setup], [symbol bars].
- 5** Move the marker to the peak impulse (this is the main signal path):
Press **[Shift]**, **[Marker]**.

The marker readout shows the main impulse at 0 seconds with approximately 0 dB of loss.

- 6** Move the marker to the next peak (this is the second signal path):
Press **[Marker Search]**, [next peak].

The marker readout shows the second signal path at -800 ns with approximately 15 dB of loss relative to the main impulse (the strongest path).

- 7** Move the marker to the next peak (this is the third signal path):
Press [next peak] again.

The marker readout shows the third signal path at $3\text{ }\mu\text{s}$ with approximately 20 dB of loss.

The impulse response in this example shows several peaks. The three highest peaks correspond to the main signal path plus two multi-path signals. The remaining peaks correspond to the two multi-path signals, as described in the next paragraph.

Each point in the impulse-response display corresponds to a tap in the feed-forward equalizer (FFE). In a FFE, large coefficients that are separate from the main tap correspond directly to alternate signal paths. The smaller peaks are a result of the same alternate signal paths that created the large peaks. In other words, a signal with one strong alternate path will have more than two impulses on the display (the main impulse and the impulses due to the alternate path). The additional impulses will be lower than the two main impulses.

In this example, the signal has 3 paths. The strongest path is not the shortest path. The shortest path passed through a building causing it to be attenuated. Normally, the strongest path will be the shortest, or direct path.

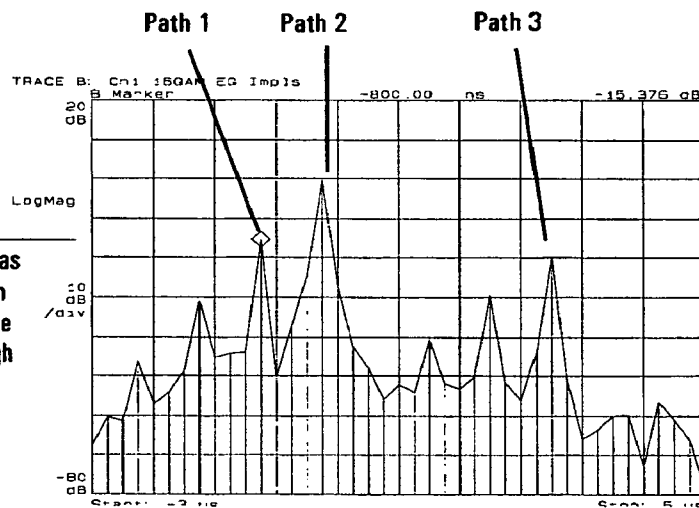

Using the impulse-response display to measure multi-path signals.

To learn more about equalization

Adaptive equalization is a powerful feature that you can use in many applications. The following paragraphs include additional information that may help you use adaptive equalization for your application.

- The primary application of the equalizer's *impulse-response* display is for evaluating multi-path environments. Multi-path environments usually require longer filter lengths.
- The primary application of the equalizer's *frequency-response* display is for evaluating the transmitter or receiver signal-path for errors such as passband ripple and group-delay distortion. Short filter lengths usually work well for these types of measurements.
- By default, the equalization filter has a unit impulse response (only one tap in the filter has a non-zero value and data simply passes through the filter). The position of the unit impulse is a function of the filter length and is positioned to provide the most optimum efficiency for most situations. The position cannot be adjusted.

- The filter length and points/symbol determine the number of taps in the equalization filter, as follows:

$$\# \text{ Taps} = ((\text{filter_length} - 1) \text{ times } \text{points_per_symbol}) + 1$$

Press [**Instrument Mode**], [demodulation setup], [equalizer], [eq filter len] to set the filter length. Press [**Time**], [points/symbol] to set the points/symbol.

- Generally, there is no advantage to using more than 2 points/symbol when using equalization. You may want to use more than 2 points/symbol for better resolution of such displays as eye diagrams, but the tradeoff is slower measurement speed.
- To see the channel frequency-response over the entire bandwidth of your signal, use 2 points/symbol or greater. You cannot see the channel frequency-response over the entire bandwidth of your signal if you use 1 point/symbol.
- Online help for the equalization-filter softkeys includes additional information. Select Digital or Video demodulation, then press [**Help**], [**Instrument Mode**], [demodulation setup], [more] and any equalization softkey.

3

Using Band-Power Markers

This chapter shows you how to use band-power markers.

To measure band power with improved dynamic range

1 Initialize the analyzer:

Press **[Preset]**.

Press **[Instrument Mode]**, [receiver], [RF section 10-10 MHz].

Press **[Instrument mode]**, [Vector].

Press **[System Utility]**, [memory usage], [configure meas memory], [num math temp], 5.

2 If your analyzer has the optional second input channel installed, turn it off:

Press **[Input]**, [channel 2], [ch2 state off].

3 Supply a signal from the internal source:

Connect the SOURCE output to the INPUT with a cable.

Press **[Source]**, [source on], [sine freq], 5 [MHz].

4 Select video averaging:

Press **[Average]**, [average on].

5 Display the same spectrum measurement in two grids:

Press **[Display]**, [2 grids].

Press **[B]**.

Press **[Measurement Data]**, [spectrum] or [spectrum ch1] (for a two channel analyzer).

6 Measure the power in the source signal with a single marker:

Press **[A]**, **[Shift]**, **[Marker]** to put the marker on the peak.

7 Measure the power in the source signal with band power markers:

Press **[Marker Function]**, [band power markers], [band pwr mkr on].

Press [band center], 5 [MHz].

Press [band width], 2 [MHz].

For a sinusoid in vector mode, the peak marker and the band power marker will report nearly identical results.

8 Measure the noise power in an adjacent band:

Press **[B]**, **[Marker Function]**, [band power markers], [band pwr mkr on].
 Press [band center], 7 [MHz].
 Press [band width], 2 [MHz].

In this measurement, the analyzer's receiver is contributing much of the noise. Using waveform math and data registers, it is possible to calibrate out much of the noise and improve the dynamic range of this measurement by as much as 10 dB.

9 Measure the input noise with the source disabled:

Press **[Source]**, [source off].
 Press **[Average]**, [num averages], 100 [enter].
 Press **[Meas Restart]**.

10 When the average count reaches 100, save the spectrum measurement of the noise floor into a data register:

Press **[A]**, **[Save/Recall]**, [save trace], [into D1]

11 Create a math function to subtract the instrument noise from the spectrum measurement:

Press **[Math]**, [define F1].
 Press [operation], [SQRT].
 Press [meas data], [spectrum ch1], [*], [meas data], [spectrum ch1].
 Press [-], [data reg], [D1], [*], [data reg], [D1].
 Press [)], [enter].

The math function should read $F1 = \text{SQRT}(\text{SPEC1} * \text{SPEC1} - \text{D1} * \text{D1})$.

Note

The math function takes this form because the spectrum results have units of volts. To convert the units from voltage to power, the spectrum data should be multiplied by its conjugate. The conjugate operation has been left out of this particular equation because the imaginary component is zero when averaging is enabled. A conjugate operation would not change the result—only the speed at which it is calculated. The SQRT() operation forces the math result to have units of volts. The selection of [magnitude log(dB)] in the **[Data Format]** menu causes the displayed result to be displayed in power units

12 Select the math function as the new result in both traces:

Press **[A]**, **[Shift]**, **[B]** to select both traces.
 Press **[Measurement Data]**, [math func], [F1].

Using Band-Power Markers

13 Turn the source on and restart the measurement:

Press [Source], [source on].

Press [Meas Restart].

The signal power should be the same as before. The noise power displayed in trace B should be eight to ten dB lower than before.

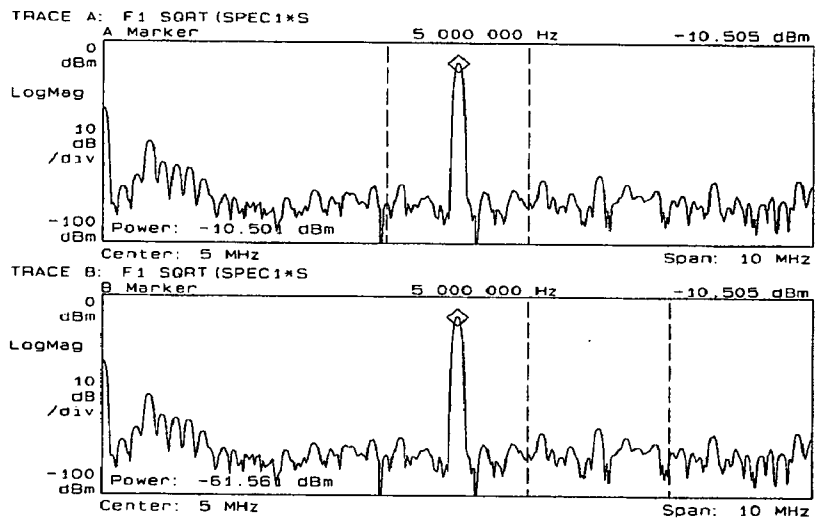

Band power measurement

4

Using the LAN

This chapter shows you how to configure and use the analyzer's LAN interface. X-Windows operation and FTP (File Transfer Protocol) are available only in analyzers that have option UG7 (Advance LAN).

To determine if you have option UG7

- 1 Turn on the analyzer.
- 2 Press [LAN setup]. If softkey F4 is [X11 display on/off], you have option UG7. If the [X11 display on/off] softkey does not exist, you do not have option UG7.

Option UFG, the LAN interface, is standard in all HP 89441V analyzers. This option lets you use telnet or C-programs to send HP-IB commands to the analyzer via the LAN.

Option UFG consists of a single printed circuit board (card) that contains 4 MegaBytes of memory, a LAN interface, and an additional HP-IB port. The LAN interface provides Ethernet (IEEE 802.3) LAN compatibility and has two LAN ports: a ThinLAN BNC and a 15-pin AUI (MAU) connector. The additional HP-IB port is a controller-only port that communicates with external HP-IB devices, and provides a simple way to program external receivers (such as downconverters) without tying up the primary HP-IB port or system controller. For details on using external receivers, see "Using the HP 89411A Downconverter."

Option UG7 enhances option UFG. This option provides remote X-Windows capabilities, which lets you view the analyzer's display and control the analyzer from across the building or across the world. Option UG7 also includes FTP (File Transfer Protocol) software. You can use FTP to transfer data to and from the analyzer.

To order option UG7 (Advanced LAN Support), contact your local Hewlett-Packard Sales and Service Office.

To connect the analyzer to a network

- 1 Turn off the analyzer.
- 2 If your network uses ThinLAN BNC cables, connect one of them to the ThinLAN connector on the analyzer's rear panel.
or
If your network uses MAUs, connect one of them to the AUI Port connector on the analyzer's rear panel.
- 3 Turn on the analyzer.
- 4 Press **[Local/Setup]**, **[LAN setup]**, **[LAN port setup]**.
- 5 Press **[port select]** to display the option corresponding to the connector you used in step 2: either "ThinLAN (BNC)" or "AUI (MAU)."

The ThinLAN connector only allows you to connect the analyzer to a ThinLAN network. However, the AUI Port lets you to connect the analyzer to ThinLan, ThickLAN, or StarLAN 10 networks via the appropriate off-board MAU. (These networks are Hewlett-Packard's implementation of IEEE 802.3 types 10BASE2, 10BASE5, and 10BASE-T.)

The analyzer should be connected to a network by only one of its LAN connectors. Check with your network administrator if you have any other questions about the LAN connections.

To set the analyzer's network address

- 1** Ask your network administrator to assign an Internet Protocol (IP) address to your analyzer. Write down the address for use in step 4.
- 2** If your analyzer must communicate with computers outside of the local subnet, ask your network administrator for the IP address and subnet mask required to route data through the local gateway. Write down these values for use in steps 5 and 6.
- 3** On the analyzer, press **[Local/Setup]**, [LAN setup], [LAN port setup].
- 4** Press [IP address], type the address obtained in step 1, then press [enter].
- 5** If you obtained a gateway address in step 2, press [gateway IP], type the address, then press [enter].
- 6** If you obtained a mask value in step 2, press [subnet mask], type the value, then press [enter].
- 7** Turn off the analyzer, then turn it back on to make the new settings permanent.

You must enter the addresses and the subnet mask using dotted decimal notation (for example, 13.1.212.66). You can disable gateway routing by setting [gateway IP] or [subnet mask] to 0.0.0.0.

To activate the analyzer's network interface

- 1 Press **[Local/Setup]**, **[LAN setup]**, then press **[LAN power-on]** to display "active."
- 2 Turn off the analyzer, then turn it back on to make the new setting permanent.

When you are not using the network interface, you should press **[LAN power-on]** to display "inactive." This will free additional memory for other uses.

To send HP-IB commands to the analyzer

- 1** Confirm that the first four tasks in this chapter have been completed.
- 2** If you do not know the network address of your analyzer, press **[Local/Setup]**, **[LAN setup]**, **[LAN port setup]**, then write down the value displayed under **[IP address]**.
- 3** On the computer, type: `telnet <IP_address>`
(where `<IP_address>` is the network address of your analyzer).
- 4** On the computer, type the HP-IB command that you want to send to the analyzer. For example, to query the analyzer for its center frequency, type:
`FREQ: CENTER?`
- 5** To end your telnet session, type `<Ctrl><D>`.

The computer you use to send HP-IB commands to the analyzer must be attached to the network and configured with software that supports the TELNET protocol. For additional information about using telnet, refer to the documentation that came with your TELNET software.

To select the remote X-Windows server

- 1** Determine the IP address of the computer you will use for remote X-Windows operation. (Ask your network administrator for help if you don't know how to do this.) Write down the address for use in step 3.
- 2** Press [Local/Setup], [LAN setup].
- 3** Press [X11 IP address], type the address obtained in step 1, then press [enter].

After you have attached the analyzer to the network and configured it as described in the previous two tasks, you can operate it remotely from any computer that is attached to the network and running X-Windows. This task shows you how to select the computer you want to use for remote operation. The next task shows you how to initiate remote operation.

Remote X-Windows is available only in analyzers that have option UG7. To determine if your analyzer has option UG7, see the task: "To determine if you have option UG7."

To initiate remote X-Windows operation

- 1** Confirm that the previous six tasks have been completed.
- 2** On the remote computer (selected in the previous task), position the mouse pointer in one of the windows, then enter the following command: `xhost +`
- 3** On the analyzer, press **[Local/Setup]**, **[LAN setup]**.
- 4** Press **[X11 display]** to display "on."
- 5** On the remote computer, use the mouse to position the outline of the remote X11 display, then click the left mouse button to continue.

When you complete this task, the outline of the remote X11 display is filled in with a replica of the analyzer's front panel. The computer maintains this replica by using its LAN connection to get the latest trace, and state information, from the analyzer.

You may find that the computer responds more slowly to other processes (for example, key presses and mouse movements) while it is maintaining the X11 display. If it responds too slowly, you can decrease the value of **[rate limit]**, which is located under **[Local/Setup]**, **[LAN setup]**. This allows the analyzer to respond more quickly to other processes by reducing the amount of time it spends maintaining the X11 display.

Remote X-Windows is available only in analyzers that have option UG7. To determine if your analyzer has option UG7, see the task: "To determine if you have option UG7."

To use the remote X-Windows display

- 1 Confirm that the previous task has been completed.
- 2 Use the instructions in the following paragraphs to control the analyzer from the remote X-Windows display.
 - To press a key. Place the cursor on the key, then click the left mouse button.
 - To activate shifted key functions. Place the cursor on the **[Shift]** key, then click the left mouse button. (Text is now displayed in blue on keys with shifted functions.)
 - To modify parameters. Click on the key that activates the parameter you want to modify, use the computer's keyboard to type the new text or number, then click on **[enter]** (or the appropriate units key.)
 - To turn the knob. Place the cursor on the knob, then click the right or left mouse button to turn it; right turns it clockwise, left turns it counter-clockwise.
 - To position the marker. Place the cursor on or near the trace at the desired x-axis location, then click the left mouse button.

You may want to pause the analyzer before changing its configuration via the X-Windows display. The analyzer can respond more quickly to these changes when it is paused. Click on **[Pause|Single]** to pause the analyzer.

Remote X-Windows is available only in analyzers that have option UG7. To determine if your analyzer has option UG7, see the task: "To determine if you have option UG7."

To transfer files via the network

- 1** Confirm that the first four tasks in this chapter have been completed.
- 2** If you do not know the network address of your analyzer, press `[Local/Setup]`, `[LAN setup]`, `[LAN port setup]`, then write down the value displayed under `[IP address]`.
- 3** On the computer, type: `ftp <IP_address>`
(where `<IP_address>` is the network address of your analyzer).
- 4** On the computer, just press `<Enter>` (or `<Return>`) when you are prompted for a name and password.
- 5** If you want to list the files in the root directory, type: `ls`
- 6** Change to the directory where you want the file transfer to occur by typing:
`cd <directory>`
- 7** If the file is an ASCII file, set FTP to ASCII by typing: `ascii`. If the file is a binary file, set FTP to binary by typing: `binary`.
- 8** If you want to transfer a file from the analyzer to the computer, type:
`get <filename>`
- 9** If you want to transfer a file from the computer to the analyzer, type :
`put <filename>`
- 10** To exit FTP, type `quit`

The computer you use to transfer files must be attached to the network and configured with software that implements the following networking application: TCP/IP's File Transfer Protocol (FTP). Refer to the documentation supplied with that software for additional information about using FTP to transfer files.

You cannot transfer LIF files from the computer to the analyzer. LIF files can only be transferred from the analyzer to the computer. If you transfer a LIF file from the computer to the analyzer, the LIF file will be corrupted.

For information about the analyzer's directory structure, see the "FTP (File Transfer Protocol)" topic in online help. (Press `[Help]` `[1]` to select the online help index, use the knob or the arrow keys to highlight "FTP (File Transfer Protocol)," and press `[4]`). FTP is available only in analyzers that have option UG7. To determine if your analyzer has option UG7, see the task: "To determine if you have option UG7."

Using the HP 89411A Downconverter

The HP 89411A allows the use of the advanced analysis features of the HP 89410A (the IF Section) to be applied to signals above the frequency limit of the HP 89441V.

The HP 89411A at a Glance

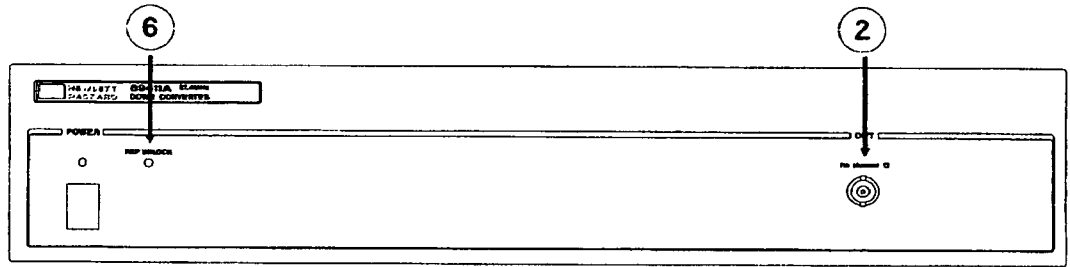

HP 89411A front panel

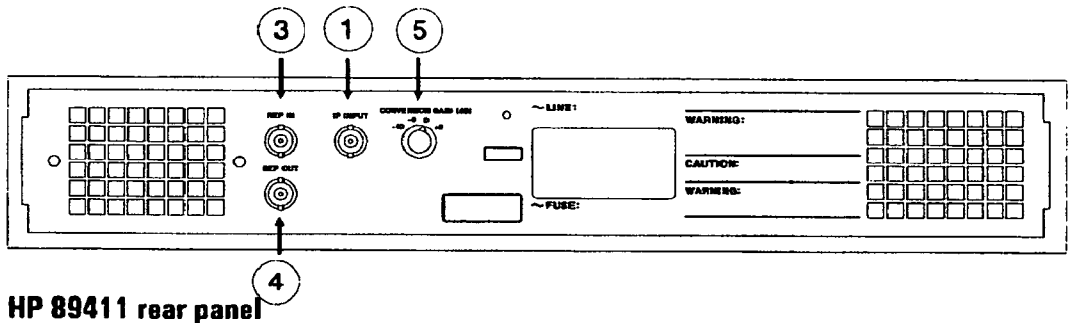

HP 89411A rear panel

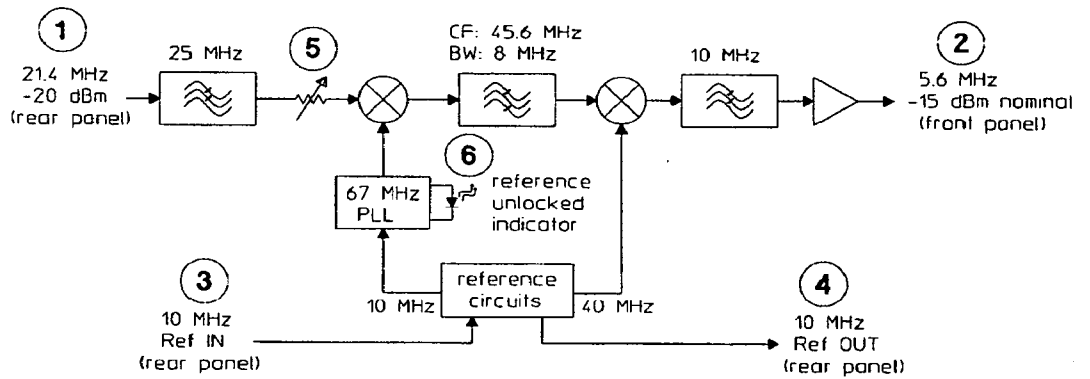

HP 89411A block diagram

Descriptions

The HP 89411A is a fixed downconverter used to translate the 21.4 MHz IF output on several Hewlett-Packard RF/microwave spectrum analyzers to a baseband frequency within the range of the HP 89410A. It translates the entire IF bandwidth to a baseband frequency centered at 5.6 MHz. The conversion gain of the HP 89411A can be varied to be compatible with several different spectrum analyzers.

The following describes elements appearing in the front and rear panel illustrations, the block diagram, and the setup diagram (on the next page).

- 1** (rear) The IF Input connector. This is a 21.4 MHz signal from the rear panel of an RF or microwave spectrum analyzer. The input signal level should be approximately -20 dBm to achieve optimum performance from the HP 89411A.
- 2** (front) The Output connector provides a 5.6 MHz signal that goes to the Channel 1 input connector on the HP 89410A Vector Signal Analyzer. This signal should be approximately -15 dBm. The downconversion gain step attenuator **5** may be adjusted to change the gain.
- 3** (rear) The Reference Input connector accepts a 10 MHz reference signal from the RF or microwave spectrum analyzer.
- 4** (rear) The Reference Output connector provides a 10 MHz reference signal that goes to the HP 89410A Vector Signal Analyzer.
- 5** (rear) The downconversion gain switch controls a step attenuator that allows you to adjust the total gain of the downconverter from $+5$ dBm to -15 dBm in 5 dB steps, the goal being an output of approximately -15 dBm. When the IF Input level is -20 dBm, an attenuator setting of 0 dB yields an output level of -15 dBm.
- 6** (front) The Reference Unlocked indicator. This indicator lights when the 10 MHz reference input signal at **3** is <0 dBm, or when there is a malfunction in the HP 89411A local oscillator.

Connection and setup details for the HP 89411A

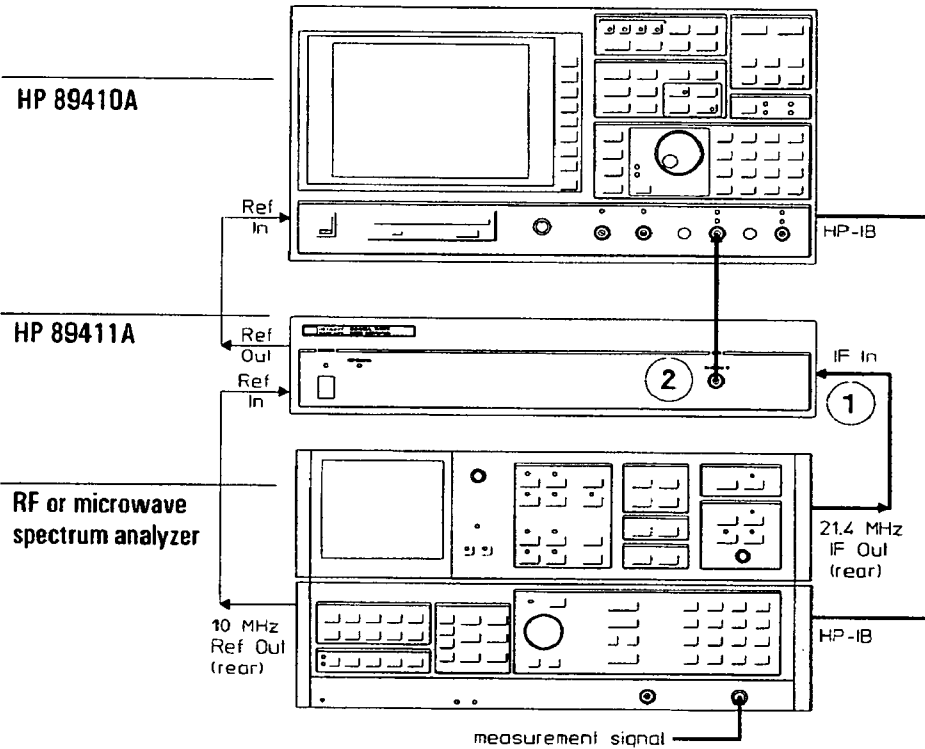

HP 89411 setup diagram

- If the RF/microwave analyzer is the HP 8566A/B:
 - 1 The frequency reference output of the HP 8566 is connected to the reference input in the HP 89411A. The reference output of the HP 89411A connects to the external reference input of the HP 89410A (both signals ≥ 0 dBm).
 - 2 21.4 MHz IF output of the HP 8566 connects to the IF input of the HP 89411A. This signal level is nominally -20 dBm when the signal level on the HP 8566 is at its reference level (top of screen).
 - 3 The (front panel) baseband output of the HP 89411A is connected to the channel 1 input on the HP 89410A. Its level is nominally -15 dBm when the step attenuator in the HP 89411A is set to the rightmost position (labeled $+5$ dB). For optimum results the input range of the HP 89410A should be set to -14 dBm.

Note

The SYSTEM INTERCONNECT port is provided only for connection to the spectrum analyzer used with the HP 89411A 21.4 MHz Down Converter.

The HP-IB address for the port is one higher than the analyzer address. For example if [Local/Setup], [analyzr addr] is 19, the address of the SYSTEM INTERCONNECT port is 20. The port is also available via IBASIC at select code 10.

The HP 8566A/B should be set up as follows:

Set the center frequency to the frequency of your signal. Set the frequency span to 0 Hz, and the resolution bandwidth to 3 MHz. The reference level should be adjusted so that the signal lies within 1 division of the top of the screen. The vertical scaling should be set to linear rather than log. You should also set the sweep time to a large value (e.g., 100 seconds) to prevent the sweep retrace from causing unwanted transients in your measurement.

- If the RF/microwave analyzer is an MMS system:

Several possibilities exist here, depending on the combination of RF and IF modules present. In addition, the frequency reference connections are more involved. The conversion gain of the system depends on which IF module supplies the 21.4 MHz IF signal, and the attenuator setting of the RF section. The nominal conversion gains in the section that follows do not include effects of frequency response of the RF section. The conversion gain is generally smaller at higher frequencies, especially for the RF sections with preselectors (e.g., 70905, 70906, and 70908). For simplicity, the stated conversion gains assume the attenuation of the RF section is set to 0 dB. However, to prevent damage to the mixer in the RF section, it is recommended that the attenuation be set to at least 10 dB. You should make sure the reference level and attenuator settings are appropriate for your measurement. The reference level should be set to a level equal to or larger than the largest signal you expect to measure.

At this time you should also set the following parameters:

Set the center frequency to the frequency of your signal and the frequency span to 0 Hz. The reference level should be adjusted so that the signal lies within 1 division of the top of the screen. You should also set the sweep time to a large value (e.g., 100 seconds) to prevent the sweep retrace from causing unwanted transients in your measurement.

The frequency reference module (70310A) should be ordered with the standard configuration (i.e., do not order opt, 002 which deletes the ovenized oscillator), unless there will always be a good externally supplied reference signal present.

- 1** If the system contains a 70902A and a 70903A IF section, the signal flow is normally from the RF section to the 70903A, then to the 70902A. The 21.4 MHz OUT port on the 70903A drives the 70902A, and the AUX 21.4 MHz OUT port on the 70902A drives the HP 89411A IF input. The conversion gain of the system is nominally -5 dB in this case.
- 2** If the system contains only the 70902A IF section, the RF section is connected to the 70902A, and the AUX 21.4 MHz OUT port of the 70902A drives the IF input of the HP 89411A. The conversion gain is nominally -5 dB.
- 3** If the system contains only the 70903A, the RF section drives 21.4 MHz input, and its 21.4 MHz OUT port drives the HP 89411A input. The conversion gain is nominally +5 dB.
- 4** If the system contains only an RF section (such as the 70904A) then the output can be taken from it directly to the HP 89411A input. The conversion gain of the RF section is nominally 5 dB.

In some of the situations previously listed, the combination of input signal level, attenuation, and IF section employed may result in a IF level at the HP 89411A input that is too large. The conversion gain switch on the rear of the HP 89411A should be set to provide a lower amount of conversion gain in this case. To obtain optimum performance from the HP 89411A, its conversion gain should be set, if possible, to give -15 dBm at the HP 89411A front panel output for the largest measured signal. In some cases, the amplitude may be too small and you should lower the range setting of the HP 89411A to obtain the best dynamic range.

Example

If you have an RF signal level of $+10$ dBm into the MMS spectrum analyzer configured as previously described, you would probably want to use the following setup. The MMS spectrum analyzer's reference level is set to $+10$ dBm resulting in 20 dB of RF attenuation and the signal at the 70902A AUX 21.4 MHz OUT port is -15 dBm. The conversion gain of the HP 89411A should be set to 0 dB and the signal provided to the HP 89411A is -15 dBm, as desired.

For more complete information on MMS system components, refer to the operation manual supplied with your system, and to the *Modular Measurement System* catalog.

Using the HP 89411A Downconverter

6

Choosing an Instrument Mode

The analyzer provides three measurement modes—Scalar, Vector, and Video Demodulation. This chapter provides a brief overview of the instrument modes and guidelines for choosing which type you need for various measurement situations.

Why Use Scalar Mode?

If you've used a spectrum analyzer before, you should have no trouble making scalar measurements with this analyzer. And even if you haven't used a spectrum analyzer before, you'll find this analyzer quite easy to learn.

Scalar measurements are implemented differently than measurements in the traditional swept-tuned spectrum analyzer, but the results will appear familiar to you. For more details on the implementation of scalar measurements see "What Makes this Analyzer Different" and "Fundamental Measurement Interactions".

Scalar Measurements provide displays of amplitude versus frequency for both narrow and wide spans. Use Scalar Mode when you need:

- Very narrow resolution bandwidth with high speed
- Very low noise floor with wide spans
- High signal-to-noise dynamic range
- Maximum flexibility of span, resolution bandwidth, and speed
- Spans greater than 8 MHz

Specific examples of applications for which you would use Scalar Mode include:

- Looking at spurious signals or noise
- Looking for low level distortion products

Measurement data flow diagram for Scalar Mode

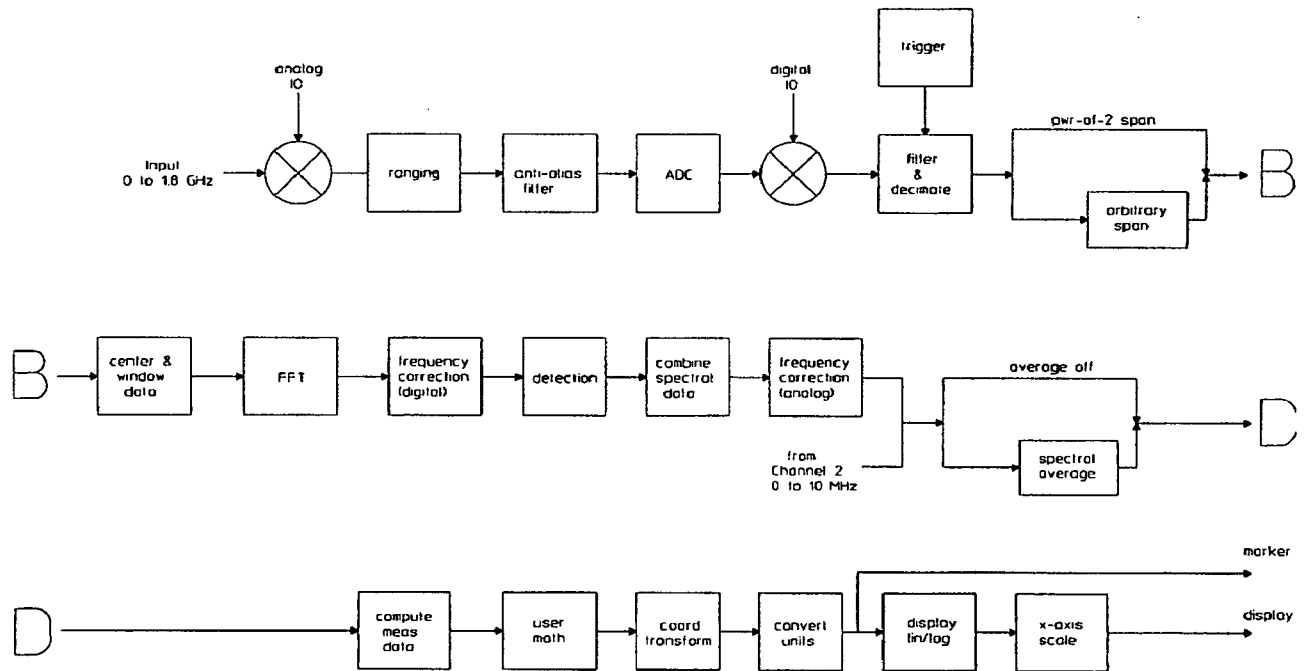

Why Use Vector Mode?

The Vector Mode provides extremely fast measurements of magnitude and phase. It can also easily change between the frequency and time domains. These capabilities are especially useful in characterizing transient or non-stationary signals.

If you've used a swept-tuned spectrum analyzer before, you already know that narrow resolution bandwidth measurements of small frequency spans are very time-consuming. Traditionally, swept-tuned analyzers have required very long sweep times for narrow resolution bandwidths due to the sweep rate of the narrow filters. The narrower the resolution bandwidth, the more time it takes for the resolution bandwidth filters to settle. In fact, a swept-tuned analyzer's sweep time is inversely proportional to the square of the resolution bandwidth. As you choose increasingly narrower resolution bandwidths (for example, when trying to resolve close-in sidebands) the time it takes to make a measurement *increases exponentially*. This characteristic is common to all conventional swept-tuned analyzers.

However, this analyzer can make narrow band measurements very quickly in Vector Mode. This lets you make measurements for spans from 1 Hz to 10 MHz (with resolution bandwidths from 9.6 mHz to 3 MHz) much faster than you can with a swept spectrum measurement. For vector measurements, the analyzer uses the FFT (Fast Fourier Transform) to convert the input signal from the time domain to the frequency domain. The result is measurement capability up to 1000 times faster than conventional swept spectrum analyzers.

If you have previously used FFT or dynamic signal analyzers, Vector measurements will seem familiar to you. However, with most FFT analyzers you are restricted to low frequency measurements, often to less than 100 kHz. But in this analyzer, Vector Mode lets you perform FFT measurements that extend beyond 1 GHz.

Use Vector Mode when you need:

- Time selective (gated) frequency domain measurements
- Time data display
- Phase information
- Time capture/playback
- Narrow span with high speed

Specific examples of applications for which you would use Vector Mode include:

- Characterizing spurious response of an oscillator
- Characterizing a burst signal in both the time and frequency domain

Measurement data flow diagram for Vector Mode

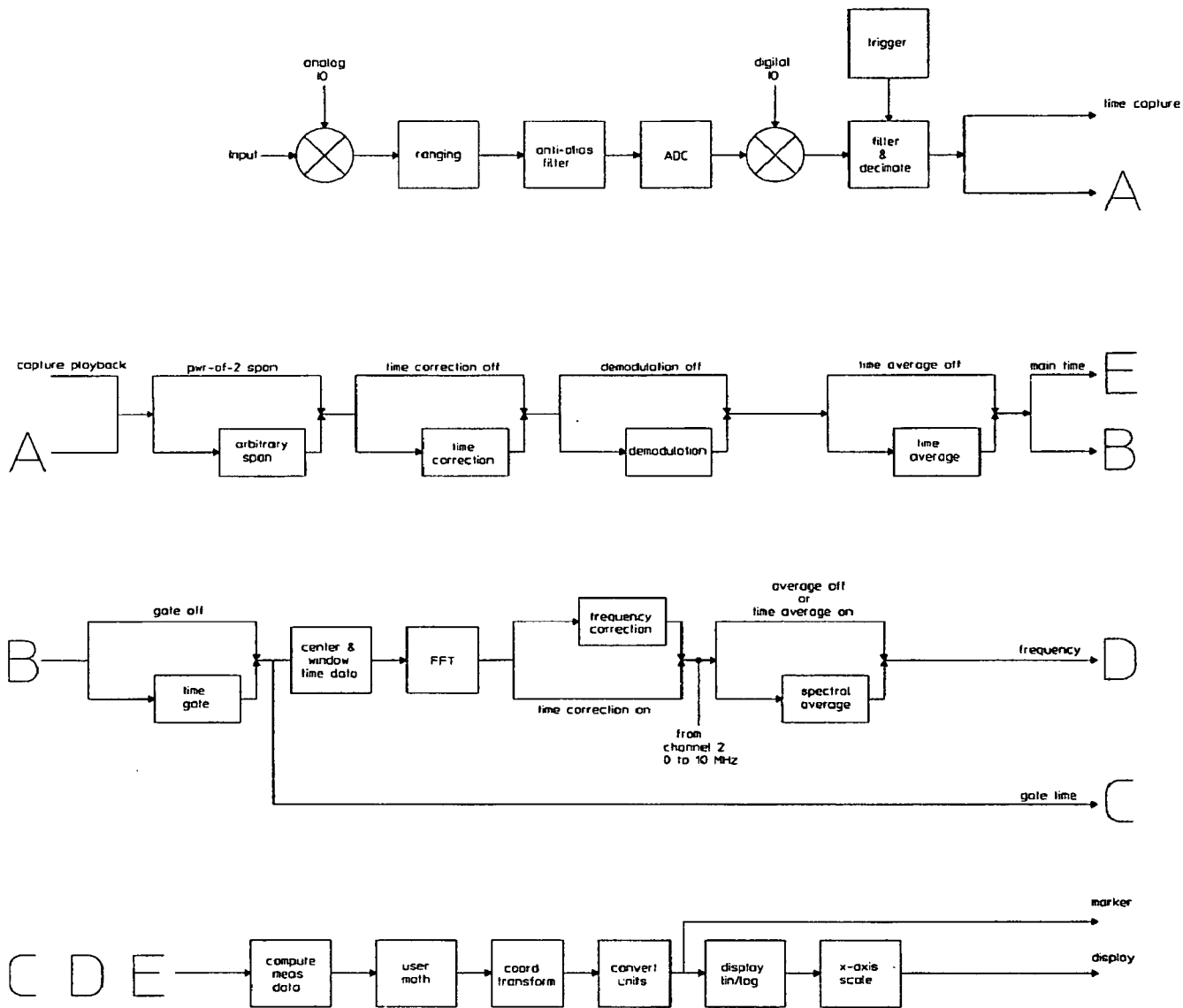

Why Use Video Demodulation Mode?

The video demodulation mode acts as a *reference receiver*. It demodulates the signal with a high degree of accuracy, enabling information to be extracted from it. This information includes a portion of the binary data stream, as well as metrics that indicate modulation (signal) quality.

With the video demodulator you may choose to:

- View eye and constellation diagrams to identify sources of modulation error such as IQ gain and phase imbalance.
- Look at phase error as a function of time or symbol to look for oscillator instability.
- Look at amplitude error as a function of time to look for distortions associated with signal amplitude.
- Use the equalizer to characterize linear distortion. For example, you can observe group delay distortion over the bandwidth of the signal.
- Measure carrier frequency while the signal is modulated.
- Use the error vector spectrum to identify spurious interference that would otherwise be invisible in the signal spectrum.
- Use quality metrics such as EVM and MER for go/no-go testing.

The Advantage of Using Multiple Modes

You can often take advantage of the analyzer's flexibility by using more than one instrument mode in a measurement scenario.

Scalar—the big picture

Use Scalar Mode to identify signals present in a wide span and to evaluate small signals very close to the noise floor. For example, in evaluating an oscillator you can use Scalar Mode to identify spurs and harmonic distortion products and evaluate them with very narrow resolution bandwidths.

Vector—the important details

After you have identified signals in a wide-span Scalar measurement, use Vector Mode to quantify and analyze the important signals with phase and time data capabilities. In the oscillator example above, you could use Vector Mode to measure oscillator sidebands.

Video Demodulation—another view of the details

After you have identified the video signal's carrier frequency in a Vector measurement, use Video Demodulation to determine the modulation (signal) quality of the video signal.

Instrument Mode? Measurement Data? Data Format?

Instrument modes

When you specify an instrument mode, you are asking the analyzer to acquire input data and process it in a certain way. For example, with the Vector Mode, the analyzer uses an FFT algorithm to convert a single time record into the most basic frequency domain measurement available—the spectrum. For Video Demodulation Mode, the signal is filtered by a matched filter and demodulation for signal quality analysis.

Look at the front panel. Notice how the **[Instrument Mode]** key is in the MEASUREMENT group. This is because anything you change from this group of keys affects the way the analyzer collects input data. In general, if you change something with these keys (such as the instrument mode, or a different start or stop frequency), the analyzer must make a new measurement.

If you look at the analyzer's front panel, you can see that both the **[Measurement Data]** and **[Data Format]** hardkeys are in the DISPLAY group. If you press a key in this group, all you are doing is selecting which type of data you want to display and how you want to display it—you aren't changing the way the analyzer makes measurements or the data that was measured.

Softkeys in the MEASUREMENT group, however do affect the way the analyzer takes input data. For example, **[Instrument Mode]** is in this group. So is **[Frequency]**, which you use to change the start and stop frequencies. So if you need to change a parameter under any of these menus (or select a different instrument mode), you will need to take new data.

Measurement data

Suppose you've selected the Vector Mode. Now you can select different types of measurement data, for example, the linear spectrum, frequency response, or main time data. No matter which measurement data selection you make, the analyzer does not have to acquire new data. When you select a type of measurement data, you are simply asking the analyzer to display a particular piece of the measurement data that's already been acquired.

Data format

Once you select both an instrument mode and appropriate measurement data, choosing a data format simply tells the analyzer how you want to look at the selected measurement data. For example, if you are in the Vector Mode and you are viewing power spectrum data, you could change the Y-axis scaling by selecting linear magnitude or logarithmic magnitude.

Unique Capabilities of the Instrument Modes

Many features and capabilities are available in all three measurement modes but others are available in selected modes. The following table shows, at a very general level, those features and capabilities which are not universal. The ensuing tables show in more details the features available in each instrument mode.

General Capabilities Unique to Specific Measurement Modes

	Scalar	Vector	Video Demodulation
Phase information	no	yes	yes
Time data	no	yes	yes
Gating	no	yes	no
Time capture	no	yes	yes
Network Measurements	no	yes	yes *
Selectable detectors	yes	no	no
Manual Sweep	yes	no	no
Very narrow resolution bandwidths	yes	no	no
Very low rbw/span ratios	yes	no	no
Spans greater than 10 MHz	yes	no	no

* with adaptive equalization

Choosing an Instrument Mode

Display Features Available by Instrument Mode

		Scalar	Vector	Video Demodulation
Measurement data	spectrum	yes	yes	yes
	PSD	yes	yes	no
	time	no	yes	yes
	frequency response*	no	yes	yes **
	math functions	yes	yes	yes
	data registers	yes	yes	yes
	coherence*	no	yes	no
	cross Spectrum*	no	yes	no
	correlation	no	yes	no
	capture buffer	no	yes	yes

* with optional second channel

** with adaptive equalization

Measurement Features Available by Instrument Mode

		Scalar	Vector	Video Demodulation
Trigger types	Free run	yes	yes	yes
	channel1 *	yes	yes	yes
	channel2	yes	yes	yes
	IF channel	no	yes	yes
	HP-IB	yes	yes	yes
	external	yes	yes	yes
Source types	CW	yes**	yes	yes
	random noise	yes	yes	yes
Average types	rms (and rms exponential)	yes	yes	yes***
	time (and time exponential)	no	yes	no
	peak hold	yes	yes	yes

- * available only in receiver modes of 0-10 MHz
- ** available only when optional RF source is disabled
- *** available for scalar results, such as EVM; not available for IQ measured reference time and IQ measured spectrum results.

What Makes this Analyzer Different?

As you become familiar with your new analyzer, you will find that most measurements look like those made with other types of analyzers with which you are probably familiar. This chapter introduces you to the reasons for the similarities, differences, and increased capabilities of this analyzer as compared to other types of analyzers.

Time Domain and Frequency Domain Measurements

Measurements made in the time domain are the basis of all measurements in this analyzer. The time domain display shows a parameter (usually amplitude) versus time. You are probably familiar with time domain measurements as they appear in an oscilloscope. Similar measurements may be viewed with the time measurement data capability.

Frequency-domain displays show a parameter (again, usually amplitude) versus *frequency*. A spectrum analyzer takes an analog input signal—a time-domain signal—and converts it to the frequency domain (this conversion can be done in several ways; we'll talk about that a little later). The resulting spectrum measurement shows the energy of each frequency component at each point along the frequency spectrum.

Many signals not visible in the time domain (such as noise and distortion products) are clearly visible in the frequency domain. Because spectrum displays show frequency components distributed along the frequency axis, it's possible to view many different signals at the same time. This is why the spectrum analyzer is such a useful tool for looking at complex signals—it lets you easily measure (and compare) the frequency and amplitude of individual components.

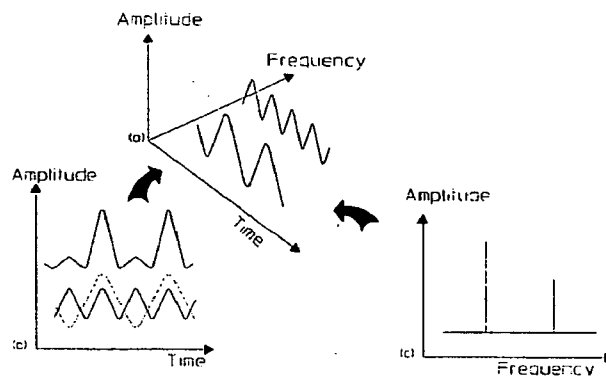

Notice the difference between the time-domain and frequency-domain displays of the same input signal.

The Y-axis (amplitude)

Time-domain measurements are usually viewed with a linear X-axis and a linear Y-axis (think of an oscilloscope). Frequency-domain measurements are sometimes viewed with a linear Y-axis and a linear X-axis, but usually must be viewed with a logarithmic Y-axis, since this is the only way to view very small signals and much larger signals simultaneously.

Let's look at the spectrum of a sine wave. Because the amplitude of any harmonic is small relative to the fundamental frequency, it's nearly impossible to view a harmonic on the same display as the fundamental unless the Y-axis scale is logarithmic. That's why most measurements made with spectrum analyzers use a logarithmic amplitude scale—a scale based on decibels. And since the dB scale is by definition logarithmic, there's no need to use logarithmically-spaced graticule lines.

The X-axis (frequency)

Sometimes it's convenient to use a logarithmic X-axis. Perhaps most familiar to you is the frequency response measurement. This is traditionally displayed with a log X-axis (frequency) versus a log Y-axis (relative magnitude).

But most measurements do not require a logarithmic frequency scale. In fact, when making spectrum measurements it's easier to characterize harmonics with a linear X-axis scale since harmonics that are multiples of the same fundamental will appear at evenly-spaced intervals.

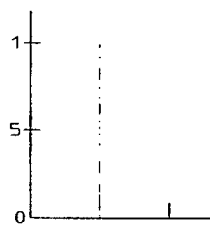

(a) Linear Amplitude Scale

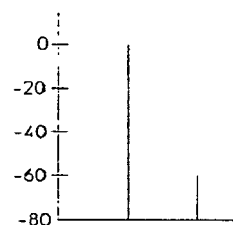

(b) Logarithmic Amplitude Scale

What are the Different Types of Spectrum Analyzers?

There are two broad categories of spectrum analyzers: *swept-tuned analyzers* and *real-time analyzers*. Both swept-tuned analyzers and real-time analyzers have been around for many years. However, within the past decade or so, spectrum analyzers have become much more sophisticated. These newer spectrum analyzers use digital signal processing to provide additional measurement capability—and let you interpret measurement results much more easily.

Both swept-tuned and real-time spectrum analyzers display amplitude versus frequency. How they process and display this information, however, varies with the specific type of analyzer. A real-time spectrum analyzer displays the energy at all frequency components simultaneously. A swept-tuned spectrum analyzer displays measurement results sequentially—in other words, not in “real time.” This is because a swept-tuned analyzer, in effect, uses a single narrow filter that is tuned across a range of frequencies to produce a spectrum display.

Swept-tuned analyzers have been the traditional choice for higher frequency applications—for example, 100 kHz and above. Real-time analyzers are generally used for lower frequencies—for example, audio-frequency and vibration measurements.

For an additional overview of spectrum/network measurements, see *Spectrum and Network Measurements* by Robert A. Witte (Prentice Hall, Englewood Cliffs, New Jersey, 1993).

Swept-tuned spectrum analyzers

Swept-tuned spectrum analyzers are descended from radio receivers. So it should come as no surprise that swept-tuned analyzers are either *tuned-filter* analyzers (analogous to a TRF radio) or *superheterodyne* analyzers. In fact, in their simplest form, you could think of a swept-tuned spectrum analyzer as nothing more than a frequency-selective voltmeter with a frequency range that's tuned (swept) automatically.

Modern swept-tuned analyzers (superheterodyne analyzers, in particular) are precision devices that can make a wide variety of measurements. However, they are primarily used to measure steady-state signals since they can't evaluate all frequencies in a given span simultaneously. The ability to evaluate all frequencies simultaneously belongs exclusively to the *real-time* analyzer.

Real-time spectrum analyzers

Despite the high performance of modern superheterodyne analyzers, they still can't evaluate frequencies simultaneously and display an entire frequency spectrum simultaneously. Thus, they are not *real-time* analyzers. And the sweep speed of a swept-tuned analyzer is always limited by the time required for its internal filters to settle.

Parallel-filter analyzers

Another way to build a spectrum analyzer is to combine several bandpass filters, each with a different passband frequency. Each filter remains connected to the input at all times. This type of analyzer is called a *parallel-filter* analyzer. After an initial settling time, the parallel-filter analyzer can instantaneously detect and display all signals within the analyzer's measurement range.

The particular strength of such an analyzer is its measurement speed—this allows it to measure transient and time-variant signals. However, the frequency resolution of a parallel-filter analyzer is much coarser than a typical swept-tuned analyzer. This is because the resolution is determined by the width of the decimating filters. To get fine resolution over a large frequency range, you would need many, many individual filters—thus increasing the cost and complexity of such an analyzer. This is why all but the simplest parallel-filter analyzers are expensive.

Typically, parallel-filter analyzers have been used in audio-frequency applications.

What Makes this Analyzer Different?

FFT analyzers

FFT spectrum analyzers (also referred to as *dynamic signal analyzers*) use digital signal processing to sample the input signal and convert it to the frequency domain. This conversion is done using the *Fast Fourier Transform* (FFT). The FFT is an implementation of the Discrete Fourier Transform, the math algorithm used for transforming data from the time domain to the frequency domain. This analyzer is an example of an FFT analyzer that can make real-time measurements.

FFT spectrum analyzers are powerful instruments, since their processing power can extract more information from an input signal than just the amplitude of individual frequency components. For example, FFT analyzers can measure both magnitude and phase, and can also switch easily between the time and frequency domains. This makes them ideal instruments for the analysis of communication, ultrasonic, and modulated signals.

If an FFT analyzer samples fast enough, all input data is evaluated and the analyzer makes a *real-time* measurement. When operating in real time, FFT analyzers can make the same measurements traditionally done with parallel-filter analyzers—and make these measurements, if desired, with far greater frequency resolution.

In the past FFT analyzers have had the disadvantage of their restricted frequency range—most FFT analyzers could not make measurements above 100 kHz. The limiting factor has been the speed of the analog-to-digital converter used to sample the analyzer's input signal. This is why swept-tuned superheterodyne analyzers are still used for RF and microwave measurements, though some newer-generation swept-tuned analyzers, such as the HP 3588A and the HP 8560 family of analyzers can also make FFT measurements. As you will see, this trend toward hybrid technology has gone one step further with the HP 89400 Series Vector Signal Analyzers.

See the related sidebar for FFT background information.

FFT Background

FFT Basics

The Fourier transform integral converts data from the time domain into the frequency domain. However, this integral assumes the possibility of deriving a mathematical description of the waveform to be transformed—but real-world signals are complex and defy description by a simple equation. The Fast Fourier Transform (FFT) algorithm operates on sampled data, and provides time-to-frequency domain transformations without the need to derive the waveform equation.

The Fast Fourier Transform (FFT) is an implementation of the Discrete Fourier Transform, the math algorithm used for transforming data from the time domain to the frequency domain. Before an analyzer uses the FFT algorithm, it samples the input signal with an analog-to-digital converter (the Nyquist sampling theorem states that if samples are taken twice as fast as the highest frequency component in the signal, the signal can be reconstructed exactly). This transforms the continuous (analog) signal into a discrete (digital) signal.

Because the input signal is sampled, an *exact* representation of this signal is not available in either the time domain or the frequency domain. However, by spacing the samples closely, the analyzer provides an excellent approximation of the input signal.

FFT Properties

As with the swept-tuned analyzer, the input to the analyzer is a continuous analog voltage. The voltage might come directly from an electronic circuit (for example, a local oscillator) or through a transducer (for example, when measuring vibration). Whatever the source of the input signal, the FFT algorithm requires digital data. Therefore, the analyzer must convert the analog voltage into a digital representation. So the first steps in building an FFT analyzer are to build a sampler and an analog-to-digital converter (ADC) in order to create the digitized stream of samples that feeds the FFT processor.

The FFT algorithm works on sampled data in a special way. Rather than acting on each data sample as it is converted by the ADC, the FFT waits until a number of samples (N) have been taken and transforms the complete block of data. The sampled data representing the time-domain waveform is typically called a time record of size- N samples.

But the FFT analyzer cannot compute a valid frequency-domain result until at least one time record is acquired—this is analogous to the initial settling time in a parallel-filter analyzer. After this initial time record is filled, the FFT analyzer is able to determine very rapid changes in the frequency domain. A typical size for N might be 1024 samples in one time record.

During the FFT process, the FFT algorithm transforms the N time domain samples into $N/2$ equally-spaced lines in the frequency domain. Each line contains both amplitude and phase information—this is why half as many lines are available in the frequency domain (actually, slightly less than half the number of lines are used, since some data is corrupted by anti-aliasing filters).

The Difference

The ideal analyzer would combine the advantages of both swept-tuned and FFT analyzers while minimizing the disadvantages. To provide these advantages the HP 89400 series analyzers use FFT technology to provide wideband and high frequency measurements as well as narrowband and low frequency measurements. The nearby figure shows the difference between the modern microprocessor-controlled swept-tuned analyzer and the HP 89400 series analyzers. The analog IF section is replaced by a digital IF section which incorporates FFT technology and digital signal processing to make very fast measurements.

Vector mode and zoom measurements

The HP 89400 series analyzers expand FFT technology to perform measurements on narrow as well as relatively wide spans from baseband to the analyzer's upper frequency limits. Earlier FFT analyzers have been limited to narrow spans and low frequencies. These limitations restricted the ability to measure phase and to analyze time-variant, transient, and modulated signals. These measurements often require real-time analysis with a non-zero start frequency and wide frequency spans. Vector mode provides a single FFT measurement as wide as 8 MHz (or 10 MHz in 0-10 MHz receiver mode). The zoom capability of Vector mode allows you to analyze spans away from DC. You may place a selected narrower span at any frequency within the analyzer's frequency range.

Stepped FFT measurements in Scalar mode

The HP 89400 series analyzers use FFT technology to provide enhanced wideband measurements. Technological advances in designing analog-to-digital converters and digital signal processors have been combined with FFT technology to provide the same results as a swept-tuned analyzer but with additional capability. The nearby diagrams reflect the differences between swept-tuned technology and stepped FFT technology.

If you are familiar with swept-tuned analyzers for making high frequency measurements you will find that the technology used in the HP 89400 series analyzers has expanded the capability to make FFT measurements with excellent resolution at higher frequency ranges. This has been accomplished by translating the highest frequencies to a lower band, then performing FFTs on separate segments of the spectrum. These segments are displayed contiguously so that the result appears as it would with a swept-tuned spectrum analyzer.

If you have previously used FFT Dynamic Signal Analyzers, you will discover that with the HP 89400 series analyzers you can select spans and resolution bandwidths which have previously been unavailable in FFT analyzers.

For low resolution bandwidths, the stepped technology in the HP 89400 series analyzers is much faster than swept-tuned analyzers. For each local oscillator step in a swept-tuned analyzer, time is required for the IF filters to settle on each input signal. With stepped technology, the largest time constraint is the time required to collect the data and perform the FFT. This results in speeds up to 1000 times faster with the new stepped technology.

What Makes this Analyzer Different?

Differences between swept-tuned and stepped analyzer technologies in IF function

Simplified block diagram of a modern swept-tuned analyzer

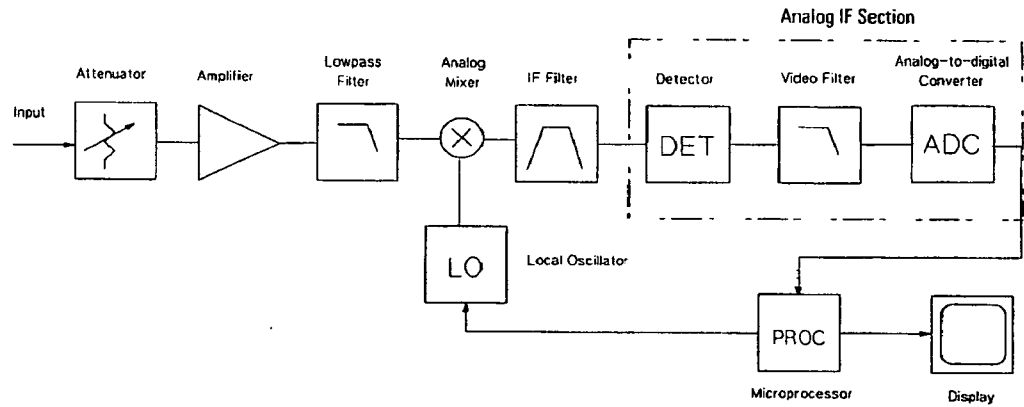

Simplified block diagram of the HP 89400 series analyzer

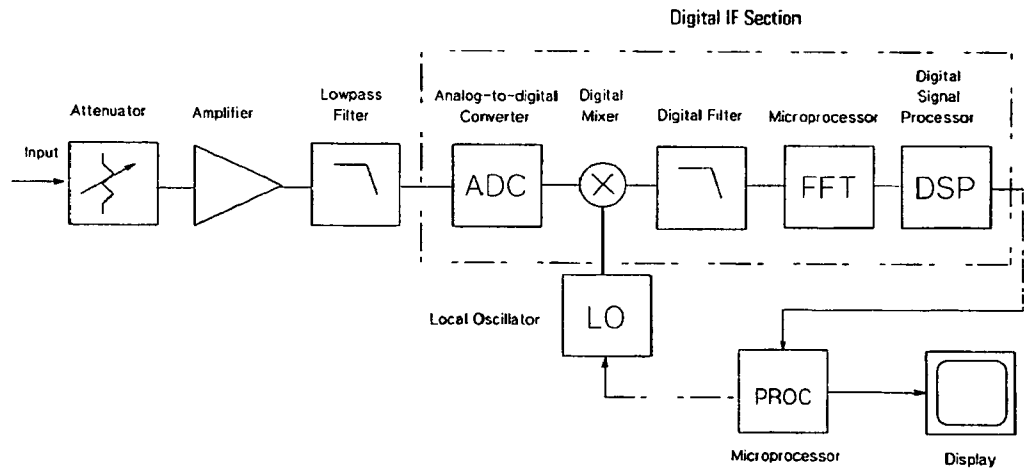

Signal flow diagram

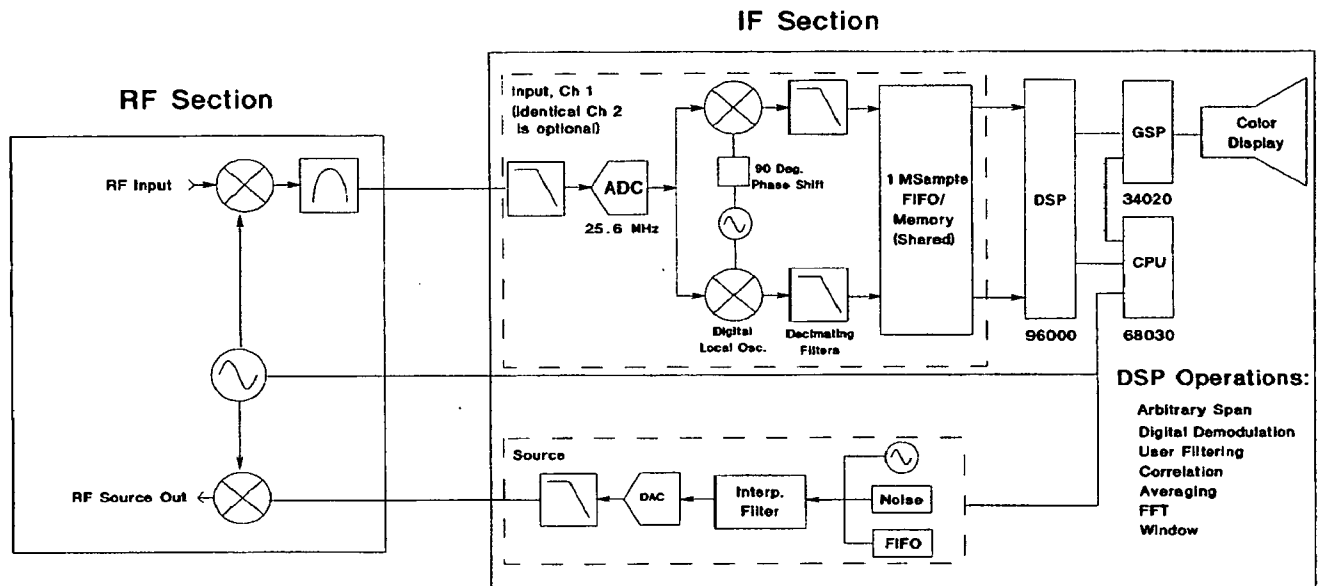

A more complete block diagram shows the complex local oscillator which allows the analyzer to use complex time analysis for phase, demodulation, and other time-related measurements.

What Makes this Analyzer Different?

The difference between swept-tuned and stepped analyzer technology in local oscillator function

A swept-tuned analyzer changes the local oscillator frequency linearly over time and measures one frequency point at a time

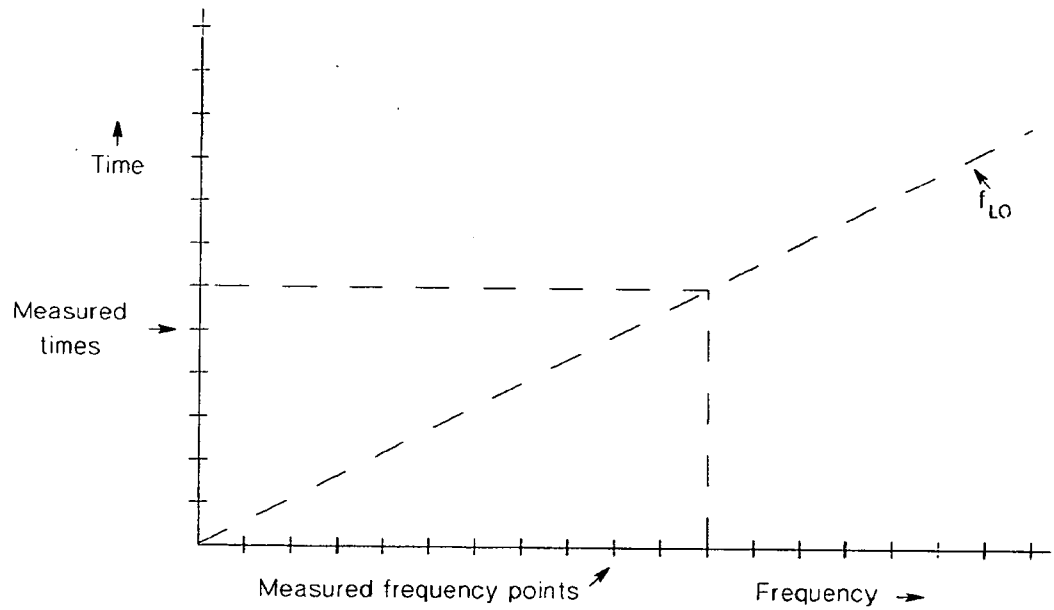

A stepped analyzer like the HP 89400 series changes the local oscillator frequency in sequential steps over time and measures multiple frequency points at one time

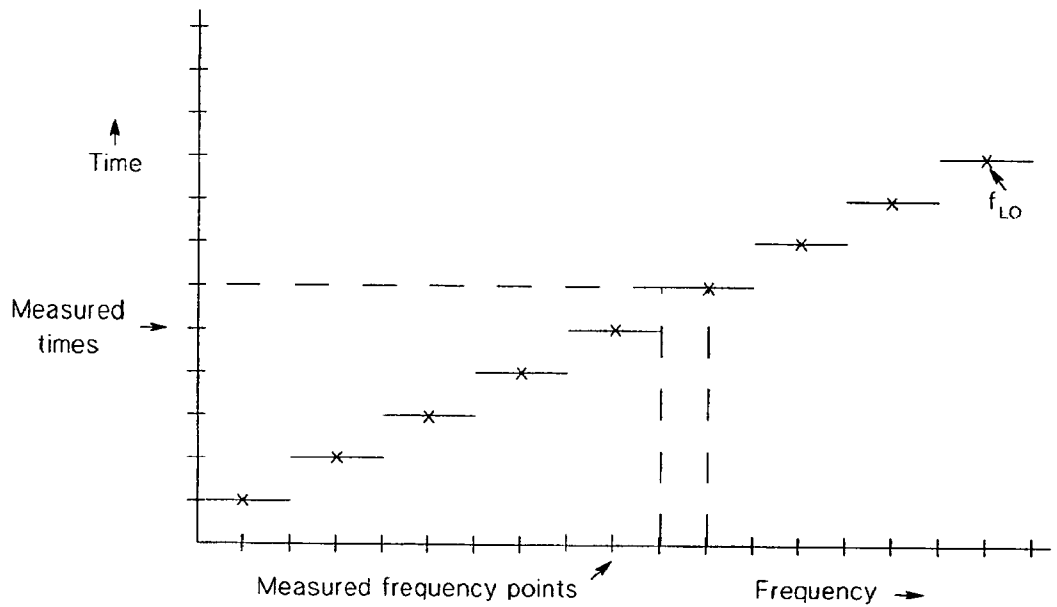

Fundamental Measurement
Interactions

Measurement Resolution and Measurement Speed

You should understand the interactions and limits related to measurement fundamentals in order to optimize your measurements. These fundamentals affect measurement speed, measurement resolution, and display resolution. If you are familiar with either swept-tuned or FFT spectrum analyzers, you will find both similarities and differences in the HP 89400 series analyzers. In any case, you should become acquainted with the material in this section in order to be comfortable with measurements in the HP 89400 series analyzers.

Resolution bandwidth, frequency span, main length, and window selection are closely related in determining measurement resolution and measurement speed. The flexible display resolution also affects your perception of measurement results.

Resolution bandwidth

Resolution bandwidth—often called RBW—determines the analyzer's frequency resolution. It may also affect how fast the analyzer makes a measurement. Normally, resolution bandwidth is adjusted automatically as you select different frequency spans. *Resolution bandwidth is one of the most important parameter settings in a spectrum analyzer.*

Because resolution bandwidth may also affect measurement time, manually selecting a narrower resolution bandwidth can slow down a measurement more than necessary. Selecting a resolution bandwidth that is too wide, on the other hand, may not provide adequate frequency resolution and can obscure spectral components that are close together.

Narrowing the resolution bandwidth lowers the noise floor because there is less noise power within the bandwidth of a narrower filter. This occurs because noise is equally distributed across the frequency spectrum, so the noise floor is lowered as you progressively restrict the range of frequencies fed to the detector algorithm.

In most analyzers, the final IF filters determine the resolution bandwidth, but in the HP 89400 series analyzers the time record length and window shape determine the resolution bandwidth—resolution bandwidth is largely independent of the span. Resolution bandwidth is related to the number of frequency points and span only when it approaches minimum and maximum limits. You will learn more about this later in this chapter.

Video filtering

In some analyzers, a low-pass filter is included between the detector and the display to smooth the noise level—in some cases revealing low-level signals that might otherwise be obscured. Other analyzers are equipped with a “video averaging” feature. This lets you average successive traces. Because video filtering and video averaging both smooth the noise floor, the results of video averaging are often similar to a single trace with video filtering.

Video averaging with the HP 89400 series Vector Signal Analyzers is actually a better approximation of noise than a video filtered-trace, since a series of averaged measurements will reveal a complete frequency span much faster than the slower progression of a single, video-filtered trace. However averaging, like video filtering, does slow down a measurement.

Frequency span

Full-span measurements let you view the entire available frequency spectrum on one display. With the HP 89410A, for example, full-span measurements extend from 0 Hz to 10 MHz. Measurements with spans that start at 0 Hz are often called *baseband* measurements.

Alternatively, you may wish to view smaller slices of the frequency spectrum. You can select any number of different spans and position these spans where you want by specifying their start or center frequencies. This process of viewing smaller spans is sometimes called *zooming* or *band-selectable* analysis. You can control the frequency span examined by specifying a center frequency and a span size. Alternatively, you can specify a start and a stop frequency to define a particular frequency span.

In the HP 89400 series analyzers, the sample rate is adjusted, based on the span, to achieve the desired information bandwidth.

Bandwidth coupling

Bandwidth coupling may be used to link resolution bandwidth and frequency span in ways which are important to understand when setting up your measurement.

The automatic adjustment of resolution bandwidth to frequency span is called "bandwidth coupling." It is an important feature and one common to most spectrum analyzers.

For most measurement situations, the default bandwidth coupling type (*auto*) provides the best compromise between frequency resolution and speed. And for most measurements, bandwidth coupling is generally preferable since it simplifies your measurement setup.

Changing bandwidth coupling

You can easily override the current resolution bandwidth selection by manually entering a setting of your own. For example, you can specify a different resolution bandwidth setting.

If you override a current resolution bandwidth setting, the analyzer remembers the adjustment you made in terms of a resolution bandwidth to span ratio. It attempts to maintain this ratio when calculating appropriate resolution bandwidth for different spans. This is called *offset coupling*. For example, if you changed to a narrower resolution bandwidth than the default (the resolution bandwidth selected automatically), the analyzer maintains a narrower-than-normal resolution bandwidth for subsequent spans. You can also specify this type of coupling by selecting [offset coupled]. This type of coupling allows the response to appear the same as the span is changed.

The other available coupling type is *fixed* coupling which maintains a resolution bandwidth setting independent of other parameter changes. For example, this allows you to change span without changing resolution bandwidth. Fixed coupling is automatically selected if you explicitly alter the analyzer's time record length.

Flexible bandwidth mode

The HP 89400 series analyzers offers two levels of flexibility in selecting a resolution bandwidth setting: *1-3-10* and *arb*. The first, 1-3-10, is the more restrictive. In this mode the analyzer always sets the resolution bandwidth at a 1×10^x or 3×10^x value. In this mode the analyzer emulates many existing spectrum analyzers. The *arb* mode allows arbitrary setting of resolution bandwidth. Your choice of bandwidth mode in conjunction with your choice of rbw coupling mode affects both resolution and speed. To get the best resolution to speed tradoff, choose *auto* rbw coupling and *arb* rbw mode.

Display resolution and frequency span

FFT analyzers have a finite record length, usually stated in number of “points,” “lines,” or “bins.” We will use the term “frequency points.” Most FFT analyzers use the same number of frequency points regardless of frequency span. However, with the HP 89400 series analyzers you may select a variable number of frequency points. The HP 89400 series analyzers have a default resolution of 401 frequency points but you may select from 51 to 3201 points of display resolution. However, for a given number of frequency points, narrower spans have finer frequency resolution. This is because the same number of frequency points represents a smaller range of frequencies.

For each frequency span, the analyzer assigns a discrete frequency value to each frequency point:

$$\text{Display resolution} = \frac{\text{Frequency span}}{\text{Number of frequency points}-1}$$

The analyzer then uses the specified start frequency to calculate nominal frequency values for each of the remaining points.

To better understand the concept of display resolution, move the main marker from display point to display point. Notice how the marker jumps to each point—you cannot put the marker between points. As you move the marker, also notice how the marker readout steps through a series of discrete frequencies that corresponds to each display point.

Display resolution is different from frequency resolution. See “The relationship between Frequency Resolution and Display Resolution” later in this chapter.

Hint

For a given display resolution and window selection, the best measurement resolution is achieved with the bandwidth mode set to *arb* and bandwidth coupling set to *auto*.

Windowing

General

A window is a time-domain weighting function applied to the input signal. A window is a filter used to compensate for the fact that most signals are not periodic within the input time record. Depending on the window, the analyzer attenuates the ends of the input time record, to prevent *leakage*—a smearing of energy across the frequency spectrum—caused by transforming signals that are not periodic within the time record.

FFT analyzers usually have several window types available. Each window offers particular advantages. Because each window type produces different measurement results (just *how* different depends on the characteristics of the input signal and how you trigger on it), you should carefully select a window type appropriate for the measurement you're trying to make.

Windowing is a concept basic to understanding FFT spectrum analyzers. To learn more, see *Spectrum and Network Measurements* by Robert A. Witte. Refer also to online help for a description of each window type and guidelines on choosing a window type.

Windows used with this analyzer

This analyzer functions as if the input signal were applied to a parallel bank of narrow-band filters (the number corresponding to the number of frequency points). The illustrations on the next page show the frequency-domain response of a single filter when using uniform, Hanning, gaussian top, or flattop windows.

The left side of each illustration represents the center of each filter. Since the filters are symmetrical, we've shown only one side of each filter response (the other side is a mirror image). The horizontal axis is normalized to $1/T$.

Think of each drawing as a template. If you position a sine frequency at the exact center of the filter, more of a sine wave's energy appears in the center bin. Some of its energy also appears in other bins. The amount of energy that spills into adjacent bins depends on the type of window you use. Frequency resolution is determined by the width of the main lobe. The Hanning window provides better frequency resolution for a fixed time record length while the Flattop window has good frequency resolution for a fixed resolution bandwidth.

Frequency response of window filters

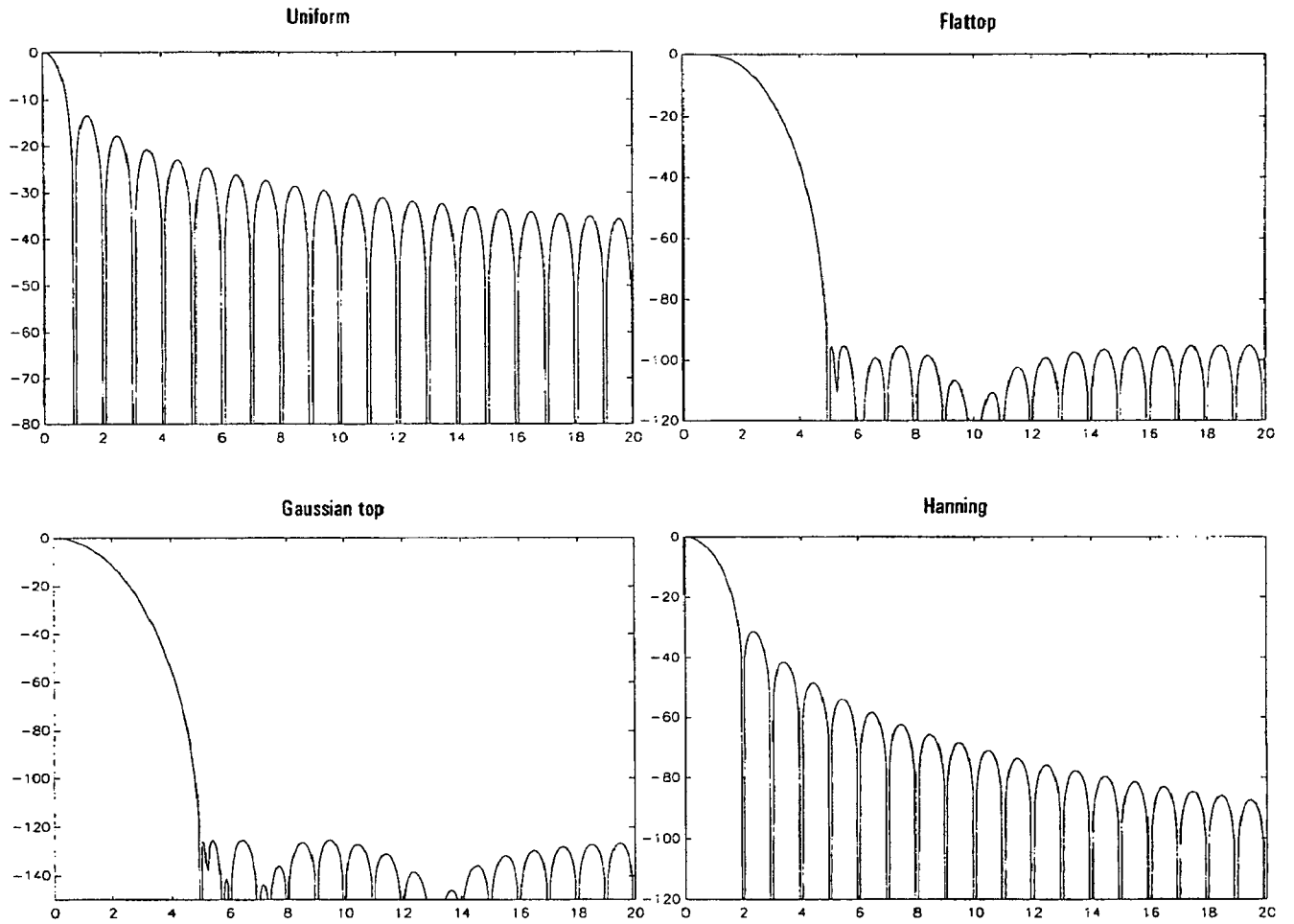

Window Comparison
(for a fixed time record) length

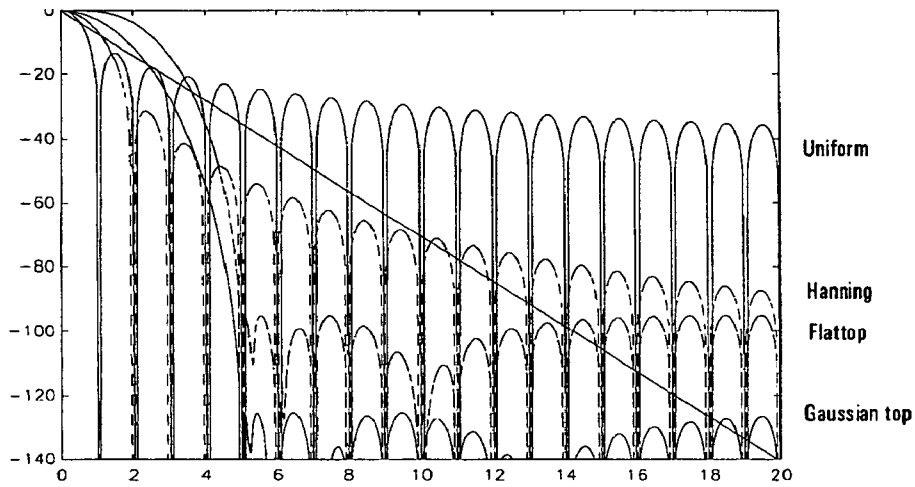

Enhancing the Measurement Speed

You can make several choices in order to maximize measurement speed:

- Turn calculation off for unused traces under **[Measurement Data]** [more choices].
- Reduce the number of frequency points to the minimum required for your measurement in order to reduce internal vector sizes. This applies to the number of frequency points selected in **[Res BW/Window]** as well as the maximum number of frequency points in memory configuration under **[System Utilities]**.
- Choose a cardinal span: $\frac{10^7}{2^n}$.
- Turn the marker off.
- If averaging is used, select fast averaging.
- If you have a two channel analyzer turn off any unused channel under the **[input]** key.
- If time calibrations are enabled, disable them.

To enhance real-time bandwidth as well as measurement speed, the following suggestions apply:

- Follow the speed enhancing suggestions above.
- Set **[rbw mode]** to arb
- Select 1601 frequency points for a single channel measurement, or 801 frequency points for a two channel measurement.
- Set **[rbw coupling]** to auto.

Digital storage

All spectrum analyzers require some form of display storage to retain, on a CRT screen, the relatively slow-moving results of a swept spectrum measurement. Early spectrum analyzers used CRTs with long-persistence phosphors (or storage meshes behind the CRT face) to maintain a visible trace throughout an entire frequency sweep. Modern spectrum analyzers use digital technology to convert the analog output from an analyzer's video detector to binary numbers in an internal memory. These values are then displayed on the analyzer's CRT screen.

Although digital storage requires a display with a finite number of frequency points, there are tremendous advantages to digitizing measurement results. Many functions, such as trace math, were unobtainable with older spectrum analyzers. Digitizing measurement results also makes it easy to save and recall traces and to transfer measurement data to other instruments (for example, over the HP-IB).

Zero response and DC measurements**What is zero response?**

When viewing frequency spans that start at 0 Hz (or very close to 0 Hz), a spectral line is usually visible at the extreme left of a spectrum analyzer's display. This is called zero response or LO feedthrough. In an FFT spectrum analyzer, zero response is caused by residual dc that originates in the analyzer's own input amplifiers. Zero response gives the illusion of a dc offset, even if the input signal has no dc component—and this occurs even if the analyzer has an ac-coupled input.

In the HP 89400 Series Vector Signal Analyzers, some degree of zero response is always present in the 0 Hz bin (sometimes called the dc bin). The residual dc that causes this offset may also leak into the first several bins as well. If you don't want to see any zero response on the analyzer's display, simply start the frequency span several bins above 0 Hz.

Can spectrum analyzers measure DC?

Most spectrum analyzers are not intended to measure dc. However, analyzers such as the HP 89400 series analyzers can measure very low frequencies. This analyzer can, in fact, measure dc, but not without including a dc offset of its own that can contribute to (or obscure) a dc offset in the input signal. As we mentioned, this internal offset is caused by residual dc that originates in the analyzer's input amplifiers. Thus, measurement performance at dc is not specified.

Special Considerations in Scalar Mode

Sweep time limitations

Sweep time is the time required for the analyzer to complete one full sweep on the display. With the standard swept-tuned analyzer, sweep time is limited by analog IF filter dynamics because the filter must have time to respond to the input signal before accurately measuring a frequency.

In the HP 89400 series analyzers the digital IF and FFT act like a parallel filter bank so the sweep speed is limited by data collection and digital processing time rather than filters. For this reason, the HP 89400 series analyzers allow measurements for low resolution bandwidths to run much faster than would be case with a swept analyzer. The sweep time is adjusted automatically—the analyzer selects the optimum sweep time, based on the frequency span, the resolution bandwidth, and the maximum number of frequency points.

Stepped measurements

Traditional swept-tuned analyzers are subject to speed and frequency limits imposed by the resolution bandwidth filters which determine the information bandwidth. Traditional FFT analyzers have been subject to fixed resolution bandwidth-to-span limitations. However, the information bandwidth of the HP 89400 series analyzers is determined by the span rather than the resolution bandwidth. Therefore, the resolution bandwidth can be changed without affecting the span.

As discussed previously in the chapter "What Makes this Analyzer Different?", the scalar measurement mode uses a stepped local oscillator to perform multiple FFTs which are then combined into a single trace. This technique, combined with digital signal processing, allows the analyzer to maximize the sweep time and overcome the fixed relationship between resolution bandwidth and span. In effect the minimum resolution bandwidth is limited only by the maximum number of frequency points and the minimum span.

The relationship between frequency resolution and display resolution

For spectrum measurements, your ability to resolve two closely-spaced components—that is, the analyzer's ability to display each component as a separate frequency point—may be limited by the display resolution. However, the maximum frequency resolution obtainable is actually determined by the resolution bandwidth you've selected. As you select increasingly narrower spans, the display resolution improves until the point where you reach the maximum resolution available with the current resolution bandwidth setting.

Resolution limited by current resolution bandwidth setting:

If the resolution bandwidth is insufficient to reveal two closely-spaced components, the detector simply sees these two components as a single frequency and displays them on as a single frequency point. The amplitude of the two components is combined, though it varies from sweep to sweep as the phase relationship between the two components changes.

Resolution limited by current display resolution:

If the display resolution is insufficient to reveal two closely-spaced components—but the current resolution bandwidth setting does provide enough resolution to distinguish two separate components—the detector uses an algorithm (peak, normal, or sample) to select a frequency component and displays it as a single frequency point. However, were you to narrow the span enough or increase the number of frequency points—keeping the resolution bandwidth constant—you would be able to view two discrete frequency components as the display resolution improved.

Resolution bandwidth limitations

The standard swept analyzer uses the last in a series of analog IF filters to determine resolution bandwidth. In contrast, the HP 89400 series analyzers use digital IF and DSP algorithm to determine resolution bandwidth. For this reason, the narrowest practical resolution bandwidth in Scalar mode is constrained by the length of time you are willing to wait for a measurement to be performed.

The widest resolution bandwidth in Scalar mode is 300 kHz for combinations of span, resolution bandwidth, and maximum number of frequency points which require that the local oscillator be stepped to more than one frequency. But for measurements which do not require that the oscillator be stepped the widest resolution bandwidth is determined by the resolution bandwidth to span ratio:

$$RBW_{\max} = .3 \times \text{span}$$

What is a detector and why is one needed

The measurement results that you view on the CRT screen are actually made up of 51 to 3201 evenly-spaced discrete frequency points. For spectrum measurements, these points represent the range of frequencies that the analyzer evaluates during each frequency sweep—extending from the currently-selected start frequency to the currently-selected stop frequency. The analyzer always uses the number of points you have selected to represent measurement data, regardless of selected frequency span or measurement type.

During spectrum measurements, the analyzer evaluates all frequencies within its displayed frequency span but it determines the number of points to display depending on the number of frequency points you have selected. The interval between frequency points represents one displayed point. Between two frequency points the signal may rise and fall a number of times. A detector determines what signal level to display for each interval.

For example, with narrow resolution bandwidths the stepped FFT measurements can result in more measurement points than were requested. When this occurs a data reduction must occur. The process of reducing the data is called detection. Detection works by combining the results of several FFT bins into a single display point. In the process of detection some information is lost. For this reason several detectors are provided, each optimized for a different purpose.

The peak, normal, or sample detector uses its own algorithm to find a suitable spectral point between the nominal frequencies that define a pair of frequency points. It transfers the amplitude of this spectral point to a nearby display point. The analyzer moves the detected point between two frequency points to the leftmost point for each pair of frequency points. For more information on how each detector type functions, display the relevant online help topics.

Manual sweep

For swept spectrum measurements, sweep times can be very long for low resolution bandwidth to span ratios. You can use *manual sweep* to disable the analyzer's automatic sweep. Manual sweep lets you tune the analyzer to a discrete frequency. This lets you measure the amplitude of discrete frequencies without waiting for the analyzer to sweep through an entire span—a considerable advantage when using a narrow resolution bandwidth.

Manual sweep is also useful when making automated measurements. Using manual sweep dramatically reduces measurement time since it's much faster to transfer amplitude data for a single frequency over the HP-IB rather than sending data for the entire display.

Special Considerations in Vector Mode

Related parameters

The characteristic time/resolution bandwidth relationship for the HP 89400 series analyzers is a natural part of the FFT process and is common to *all* FFT analyzers, not just this one. However, the HP 89400 series analyzer is unique in allowing you to change span and resolution bandwidth independently.

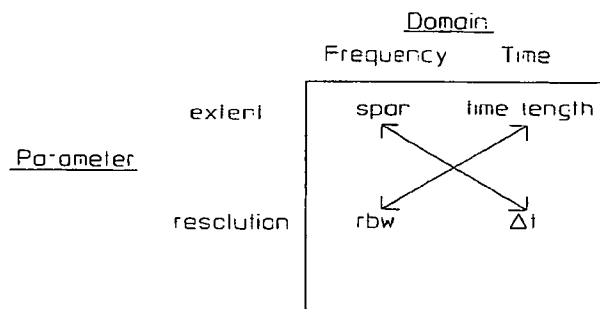

The arrows indicate inversely related parameters.

Topics later in this chapter discuss these relationships in more detail but the most important implications are:

- Resolution bandwidth changes always affect time length for a given window.
- Time length changes always affect resolution bandwidth.
- Span changes always affect Δt .
- Δt is related to sample rate and is not user-accessible—it is only affected by changing span.
- Span and resolution bandwidth may be adjusted independently.

Time data

The HP 89400 series analyzers provide the ability to view and analyze the time domain data. Time measurement data provides a time domain view of the input data before FFT processing. The following points will help you interpret time data:

- Time data is available in Vector and Demodulation modes but not in Scalar mode.
- Time data may look similar to an oscilloscope display in some cases but you will see distortion, particularly at high frequencies. The distortion occurs because the waveform is made up of the discrete samples from a time record which is optimized for FFT measurements. FFT measurements require a lower sample rate than would be required for an optimum time domain display.
- The analyzer must be in baseband mode to display data similar to an oscilloscope. In other words the measurement must start at 0 Hz and the center frequency must not be set explicitly. If you enter zoom mode either by setting the center frequency explicitly or by pressing the zoom/baseband key, a notice will flash on the screen which indicates that time data is in zoom mode. In zoom (band-selectable) measurements the time data is displayed relative to the center (local oscillator) frequency rather than relative to DC. Therefore, zoom time data has a different appearance because baseband data is real while zoom data is complex. Because the local oscillator is tuned to the center frequency for zoom measurements, the time data is represented as the difference frequency between the local oscillator and the input signal frequencies.
- Time and time exponential averaging are the only types of averaging which affect time data displays. Other average types only display the most recent time record.
- In baseband mode with maximum span, some signals, particularly square waves and transients, may appear to have excess distortion or ringing because of the abrupt frequency cut-off of the anti-alias filters. In this case the time data display can be improved by turning off the anti-alias filter under the [Input] menu. Make sure you turn the filter back on before viewing frequency domain data.

The time record

A time record is the amount of time-domain data the analyzer needs to perform one FFT operation. The time record and its FFT are the building blocks the analyzer needs for all subsequent measurements.

Why is a time record needed?

Essentially, the time record is a block of time-domain sample points. Since the actual Fourier Transform does not have explicit time or frequency references (it simply operates on a sequential collection of points), FFT analyzers must assign arbitrary start and finish times for data to be transformed. These blocks of input data are called time records.

For example, with the default display resolution of 401 frequency points, the HP 89400 Series Vector Signal Analyzer takes up to 1024 samples of time data to produce 512 points of frequency domain data. The analyzer usually displays the first 401 points of this data and discards the rest (this accommodates the anti-aliasing filters, but that's beyond the scope of our current discussion).

The time record can be described by both a *length* and a *size*. The time record length is the amount of time required to acquire a time record and is altered by changing resolution bandwidth, window, main length, or gate length. The time record size is the number of time points in the time record and is dictated by the time record length in combination with the sample rate (and sample rate, in turn, is directly related to span). More detail on these interactions can be found later in this chapter.

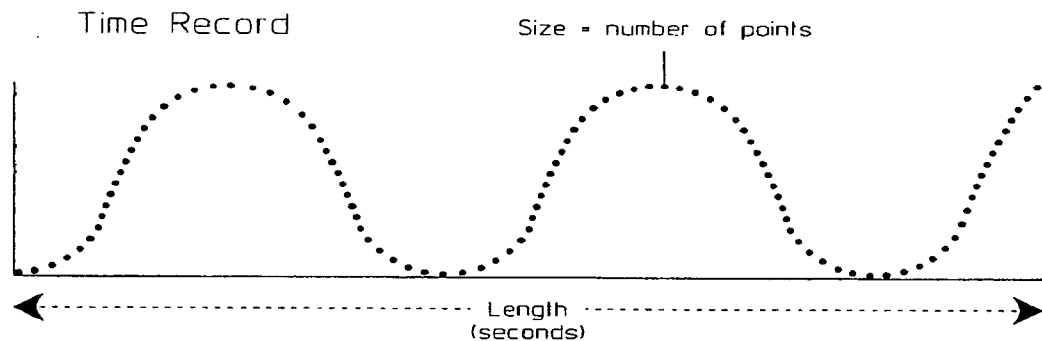

Time record size refers to the number of time points (samples) in a time record. Time record length refers to the amount of time needed to acquire a time record.

Time record, span and resolution bandwidth

The HP 89400 series analyzers eliminate a restriction inherent in previous FFT analyzers by allowing you to choose span and resolution bandwidth independent of one another. This implies a different method of handling the time record before the FFT.

The HP 89400 series analyzers take a number of samples (time points) directly related to span. These samples are acquired in a time length inversely related to the resolution bandwidth. The FFT converts this time record to the frequency domain and displays the result across the number of frequency points (display points) selected by the user.

Measurement speed and time record length

The length of a time record is inversely proportional to the resolution bandwidth. For smaller resolution bandwidths, an FFT analyzer needs a longer time record and therefore takes longer to make a measurement. For larger resolution bandwidths, an FFT analyzer needs a shorter time record and can therefore make a measurement much faster. The different time length required will become noticeable as you start making measurements. Refer to the earlier discussion: "Enhancing the Measurement Speed."

How do the parameters interact?

Window bandwidth

In most analyzers the final IF filter determines the resolution bandwidth. In the HP 89400 series analyzers the window type you select shapes the resolution bandwidth filter shape. And the window type, along with the time record length, determines the width of the resolution bandwidth filter. Therefore, for a given window type, a change in resolution bandwidth will directly affect the time record length. Conversely, any change to time record length will cause a change in resolution bandwidth.

Window Bandwidth

Flattop	3.8193596
Gaussian top	2.21234968
Hanning	1.5
Uniform	1.0

Important relationships

Window bandwidth represents the noise equivalent bandwidth of a window's filter shape and affects the resolution bandwidth and time record length:

$$T = \frac{WBW}{RBW}$$

Some useful equations help explain the relationship between time record length and time record size:

$$SR = 2.56 \times \text{span} \quad (\text{in baseband mode})$$

$$SR = 1.28 \times \text{span} \quad (\text{in zoom mode})$$

$$TP = SR \times T$$

$$\Delta T = \frac{1}{SR}$$

where:

RBW = resolution bandwidth (Hz)

WBW = window bandwidth

T = time record length (seconds)—refers to main length or gate length

TP = time record size (number of time points)

SR = sample rate (frequency)

Time record length limitations

The maximum time record size (the number of points of time data) is limited by the number of frequency points. As noted earlier, the sample rate (the rate at which data is digitized and entered into the time record) is determined by span. Therefore, the maximum time record length for a given span is determined by the number of frequency points. Because of this we can see that for a given window type, the minimum resolution bandwidth, while not directly affected by span and number of frequency points, may be limited by these parameters.

Time record size (also called block size or number of time points) is determined by window, span, and resolution bandwidth. But maximum and minimum time record sizes are determined by memory and FFT constraints:

Maximum time record length

The time record length is limited by the number of frequency points.

$$T_{\max} = \frac{(FP-1)}{\text{span}}$$

Where:

FP = number of frequency points

Maximum time record size

The time record size is also limited by the number of frequency points.

$$TP_{\max} = 2.56 \times (FP-1) \quad (\text{In baseband mode, real data})$$

$$TP_{\max} = 1.28 \times (FP-1) \quad (\text{In zoom mode, complex data})$$

Therefore:

$$T_{\max} = TP_{\max} \times \Delta T$$

Minimum time record length

Minimum time record length is dependant on the resolution bandwidth to span ratio:

$$T_{\min} = \frac{WBW}{RBW_{\max}}$$

$$RBW_{\max} = .3 \times \text{span}$$

Time record length and memory

To increase the time record length you can increase the number of frequency points until you reach the maximum number of frequency points allocated in memory (up to a maximum of 3201). To increase time record length you may have to reallocate memory space under the [System Utility] key.

Time record processing

The relationship between a time record and the frequency data is relatively straight forward if the minimum resolution bandwidth (and therefore the maximum time record length) is used. In this case the time record size is equal to the time record size required by the FFT (which is dictated by the number of frequency points and must be a power of 2ⁿ). Therefore, the FFT converts the samples in the time record directly to display points.

If a higher resolution bandwidth is selected, the time length necessary to acquire the time samples is shorter and fewer samples are required. However, the FFT must still operate on the same time record length for display purposes, so the extra time record length is set to zero (zero padded) before the FFT process. This enables the FFT to properly convert the time record to the required number of display points without adversely affecting the frequency data.

The time record calculations

The length of the time record determines how long a given measurement will take and the maximum frequency resolution you can measure. As described above the FFT time record size may differ from the size dictated by the resolution bandwidth. The FFT record size must be a power of 2 equal to or greater than the number of frequency points.

$$TP = \text{INTEGER} \left(\frac{T}{\Delta T} \right)$$

$$TP \text{ (FFT)} = 2^n \geq FP \quad \text{for zoom mode}$$

$$TP \text{ (FFT)} = 2^n \geq (FP \times 2) \quad \text{for baseband mode}$$

The time record and zero padding

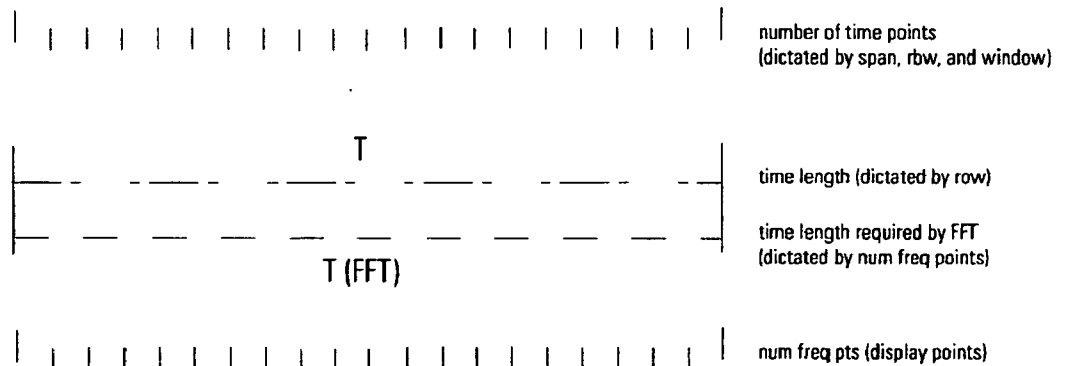

At the minimum resolution bandwidth in zoom mode, the time length necessary to collect the time samples is equal to the time record length required by the FFT.

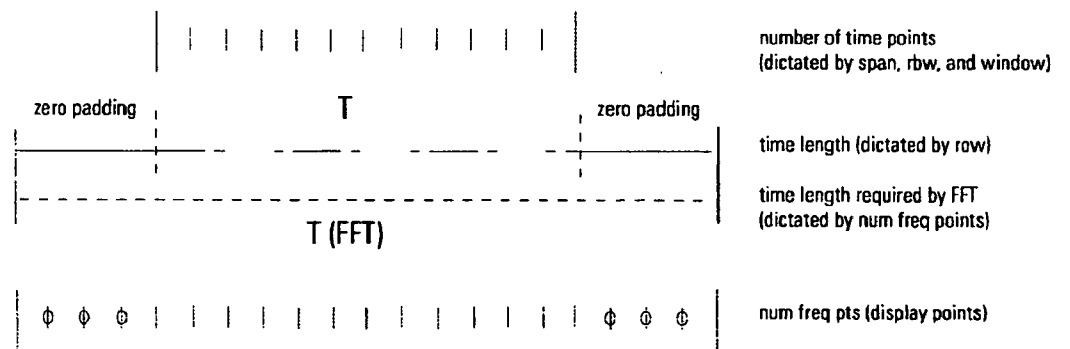

At any other resolution bandwidth, the number of frequency points remains the same, but the time required to collect the time samples is shorter than the time record required by the FFT. Therefore, the time record is extended by the addition of zeros.

Gating Concepts

What is Time Gating?

Time gating is only available in Vector Mode. Gating allows the instrument to isolate a portion of a time record for further viewing and analysis. Time gating is often used to analyze non-stationary signals or portions of stationary signals such as burst signals from devices such as videotape recorders, computer disk drives, TDMA communication bursts, or ultrasonic transducers.

Time gating lets you see a large time domain signal, only part of which you want to analyze. From the larger displayed signal, you can easily isolate a portion for further analysis.

For details on the use of the various keys related to time gating, display Online Help for the specific keys.

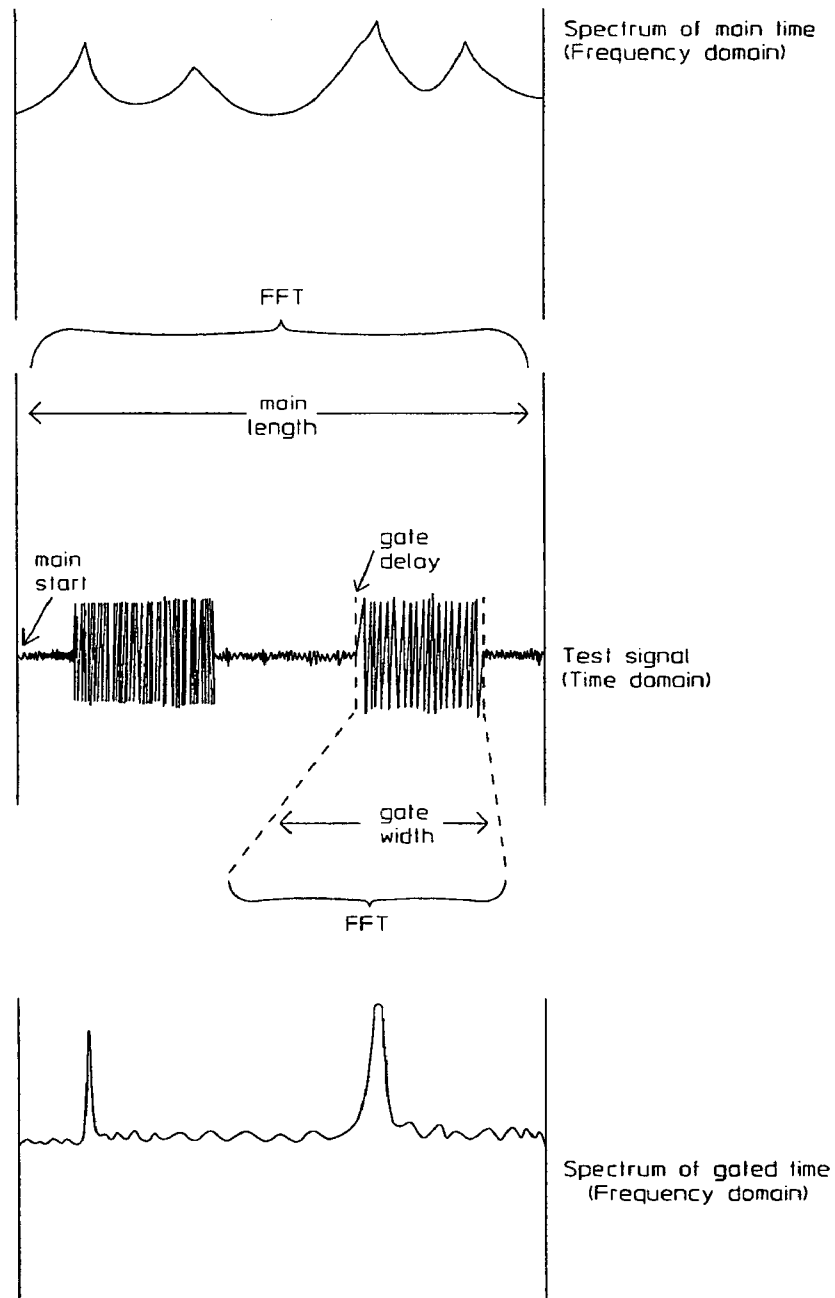

Time gating isolates a portion of a time domain signal. In this example the gated portion contains two of the four spectral components included within the total (main) test signal. Note that gating has minimized leakage, resulting in more distinct signals in the frequency domain.

How Does it Work?

The analyzer collects a record of data the duration of which is defined by main length, and the position of which is defined by trigger delay. After the main time data has been acquired, the analyzer isolates a portion of the main data as the gate record. The duration and position (relative to the start of the main record) of the gate are determined by [gate length] and [gate dly] respectively.

The gate record is then processed as the analyzer's time record. That is, spectrum, frequency response, coherence, and correlation displays are based on the gate record.

To control time gating, you define the following parameters:

- Trigger setup (if any)
- [main length]
- [ch1 gate dly]
- [gate length]

After you have acquired main time data, you may reposition or resize the gate without obtaining new main time data. The analyzer will automatically recompute and redisplay the data contained in the modified gate record.

Important Concepts

- Trigger delay and gate delays are independent for each channel—you can select different delay times for both trigger and gate regions for each channel—though lengths must be the same for both channels.
- You can smoothly scroll with the knob to change data position and length.
- You can use averaging on gated measurements. Rms and peak averaging are applied to the spectrum display of the gate, while time averaging is applied to the main time record.
- You can step the gate delay through the main time data in predetermined increments by setting [gate dly step] to the desired increment, then selecting [gate dly] and using the up and down arrow keys.
- In some applications, the overhead required to acquire a new main record may be undesirable. In this case, you may expand the gate region to cover the entire display with the [gate->main] key. You may then continue to analyze the previous gate region without collecting a large main record.
- The maximum length of the main record is determined by the span and the number of frequency points. When working in the time domain, you may not want to be limited by the selected span. In this case, you would like the span to be adjusted to meet your main record length needs. To do this, you can set [time restln] to [auto] then you may adjust main length while span is automatically adjusted to keep the number of points in the main record within the limits of the maximum number of frequency points in memory.
- You can increase the main record length by increasing the number of frequency points. You will then be able to select a narrower resolution bandwidth, longer time length, or wider frequency span.
- Resolution bandwidth cannot be independently adjusted in time gating because the resolution bandwidth is determined by the length of the time record. Since you set the length of the time record in gated measurements, you cannot set resolution bandwidth.
- If you are using gating to estimate the frequency or phase of a signal at a specific point in time, you may want to consider using demodulation instead. With demodulation you can measure the instantaneous frequency or phase at a point in time, rather than the estimate over the gate interval.

Parameter Interactions

There are some inherent parameter interactions:

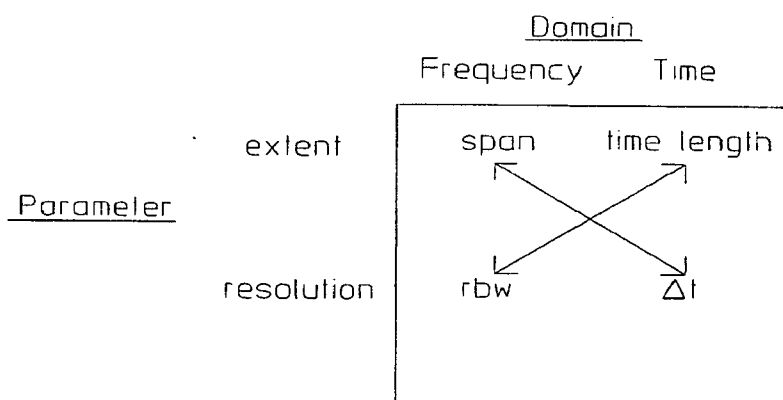

The arrows indicate inversely related parameters.

- When the gate is off, rbw and time length refer to main length. When the gate is on, these parameters refer to gate length—when you change gate length you change the resolution bandwidth. This also implies that you cannot explicitly set resolution bandwidth without changing the gate length.
- When the gate or main length are explicitly set, rbw coupling is set to fixed and rbw mode is set to arbitrary. This allows time length to be unrestricted and can therefore be set to whatever you enter.
- When rms or peak averaging is on, changing trigger delay, gate delay, main length, or gate length aborts any averaging in progress and restarts a new one. Changing the gate when time average is on does not abort the average.

10

Video Demodulation
Concepts

Overview

This chapter presents an overview of video demodulation and includes concepts to help you understand how the analyzer demodulates video signals. For examples on setting up a video demodulation measurement, see the chapter titled "Using Video Demodulation." For key-specific information, refer to online Help, which is accessed by pressing the **[Help]** key on the analyzer.

Video Modulation Analysis provides the following capabilities:

- 8 and 16 VSB (Vestigial Side Band) Demodulation
- 16, 32, and 64 DVB QAM (Digital Video Broadcast QAM) Demodulation
- 16, 32, 64 and 256 QAM Demodulation
- Mirrored (flipped) frequency spectrums so you can remove the effects of hi-side mixing.
- A maximum frequency span of 7 MHz or 8 MHz for RF measurements.

Video demodulation does not require external filters, coherent carriers, or symbol clock timing signals. Instead, the analyzer locks to the carrier and to the symbol-clock phase. The analyzer uses the demodulated signal to generate an ideal reference signal. The ideal reference signal is compared to the demodulated signal to provide a quantitative measure of system errors. The analyzer has built-in filters that may be applied to the measured signal as well as to the reference signal. This allows you maximum flexibility in comparing your signal to an ideal signal. Additionally, this allows complete flexibility to probe any analog point in your communication system. An optional second baseband channel allows IQ baseband measurement capability.

Measurement Flow

General block diagram

The Video Demodulation instrument mode uses the analyzer's digital demodulator to demodulate video signals. The following block diagram shows the location of the digital demodulator in the analyzer's block diagram.

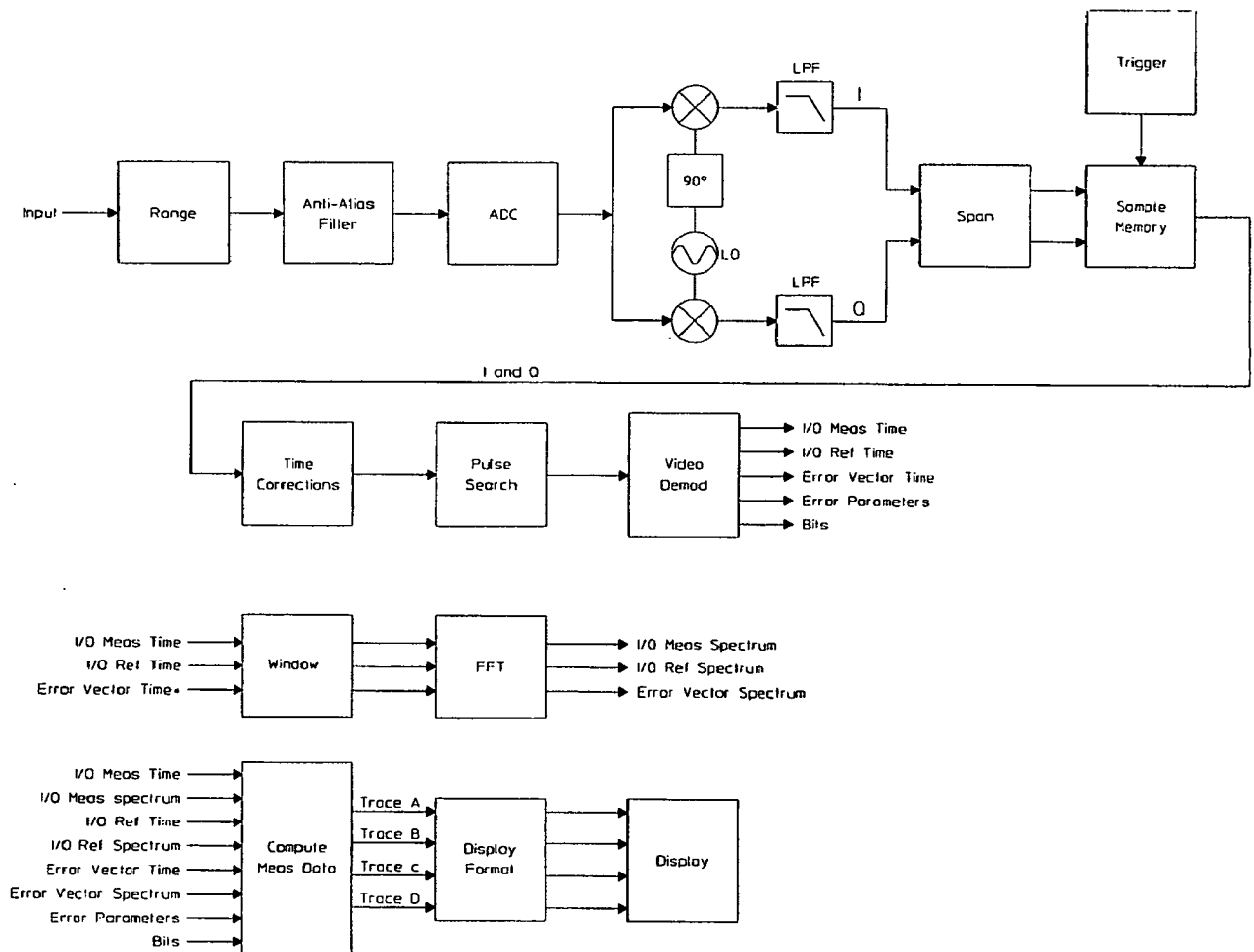

Location of Digital Demodulator in Analyzer's Block Diagram

Digital demodulator block diagram: QAM and DVB QAM

Selecting Video Demodulation reconfigures the analyzer's digital demodulator to demodulate video signals.

The following illustration shows the digital-demodulator block diagram when QAM or DVB QAM is selected. The block diagram is identical for both demodulation formats, with the following exceptions:

- Bits are decoded differently.
- I/Q origin offset is removed from QAM measurements. I/Q origin offset is *not* removed from DVB QAM measurements (but it is reported in the symbol table).

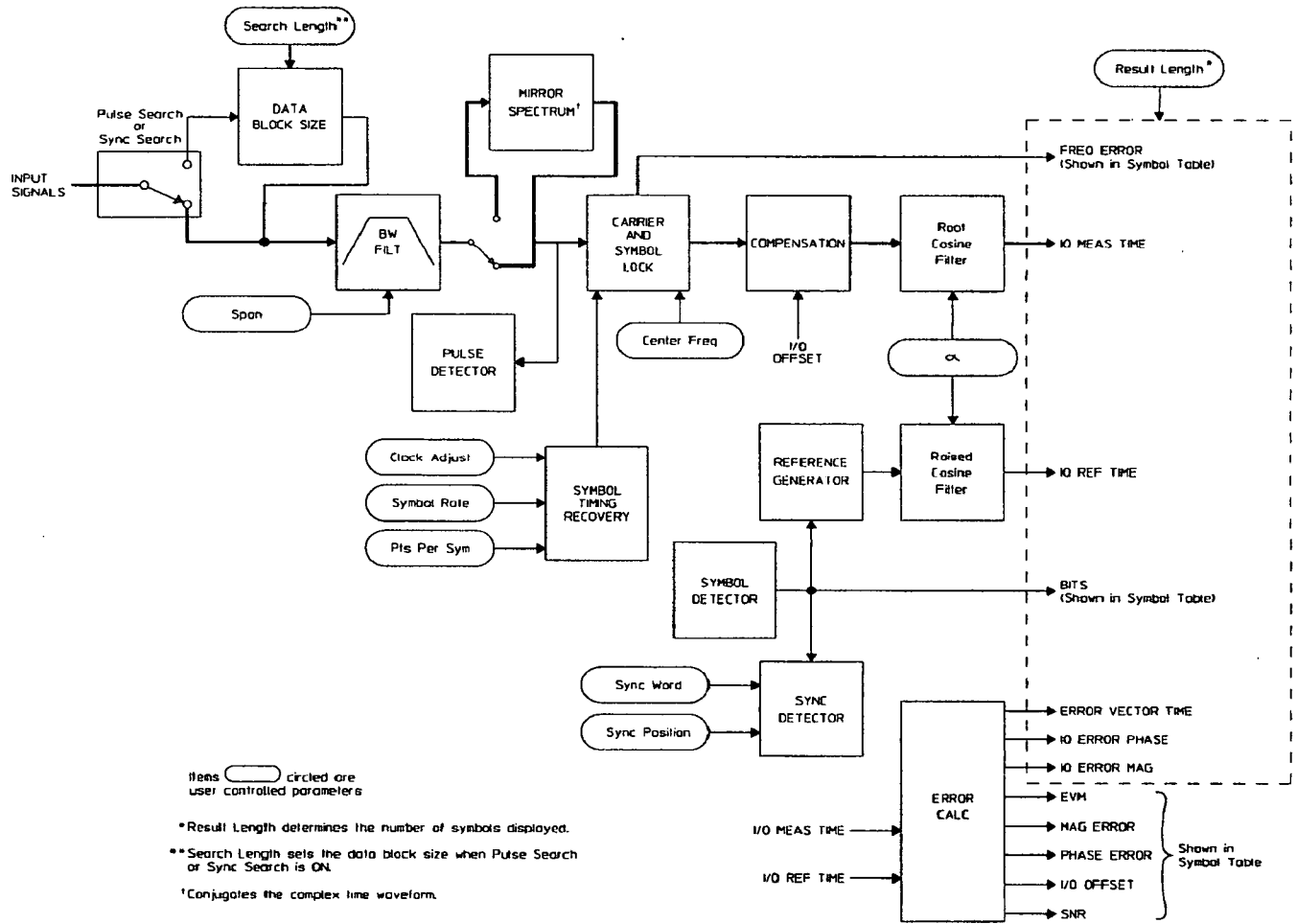

Digital Demodulator Block Diagram: QAM and DVB QAM

Video Demodulation Concepts

Digital demodulator block diagram: VSB

The following shows the digital-demodulator block diagram when 8 VSB or 16 VSB is selected.

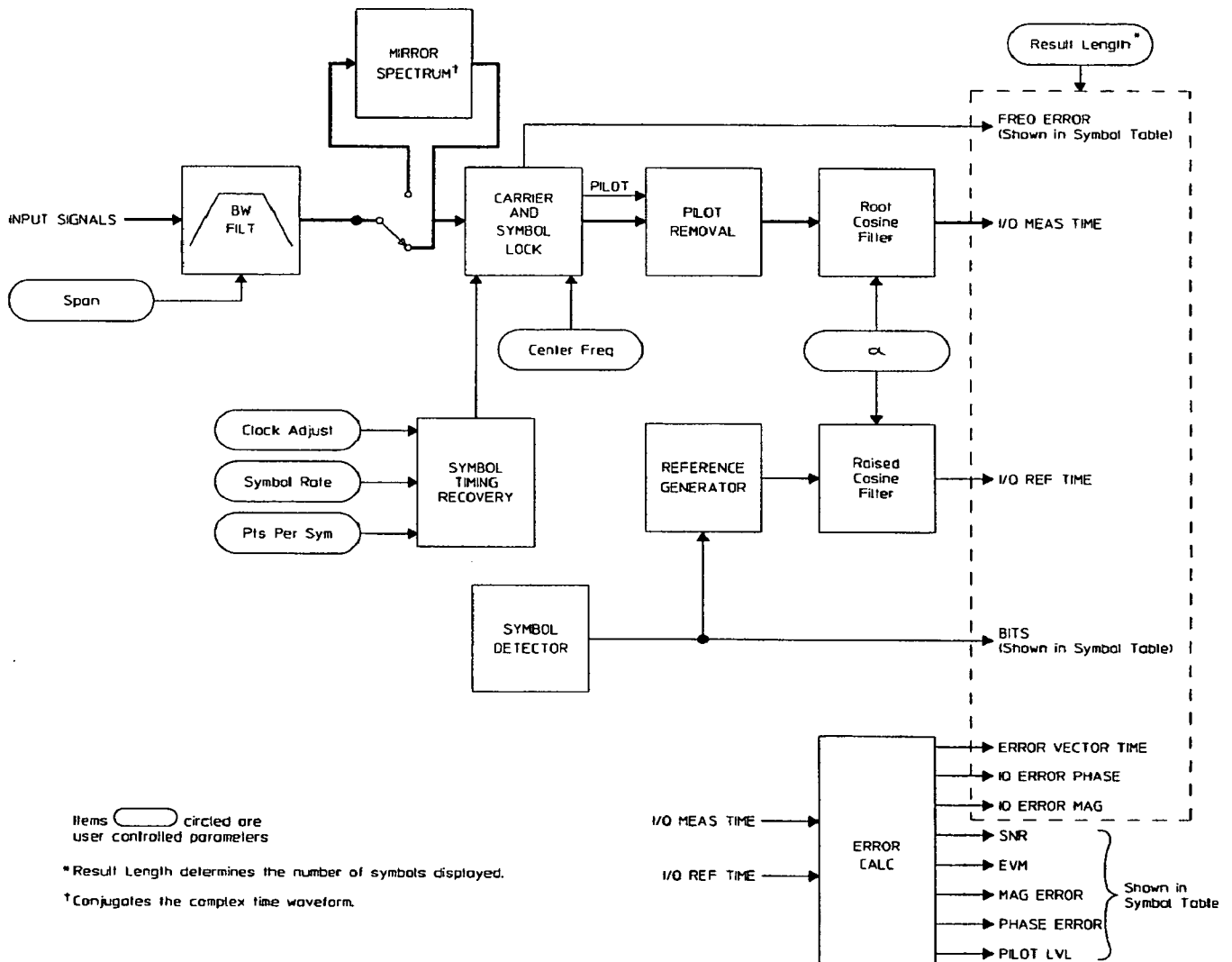

Digital Demodulator Block Diagram: VSB

Measurement management

Measurement and display choices

The flexibility of this analyzer provides numerous possible ways of viewing digitally demodulated signals. You may demodulate signals of various types then view aspects of those signals in several ways. Modulation format, measurement data, and data format may be combined in different ways for specific measurement needs.

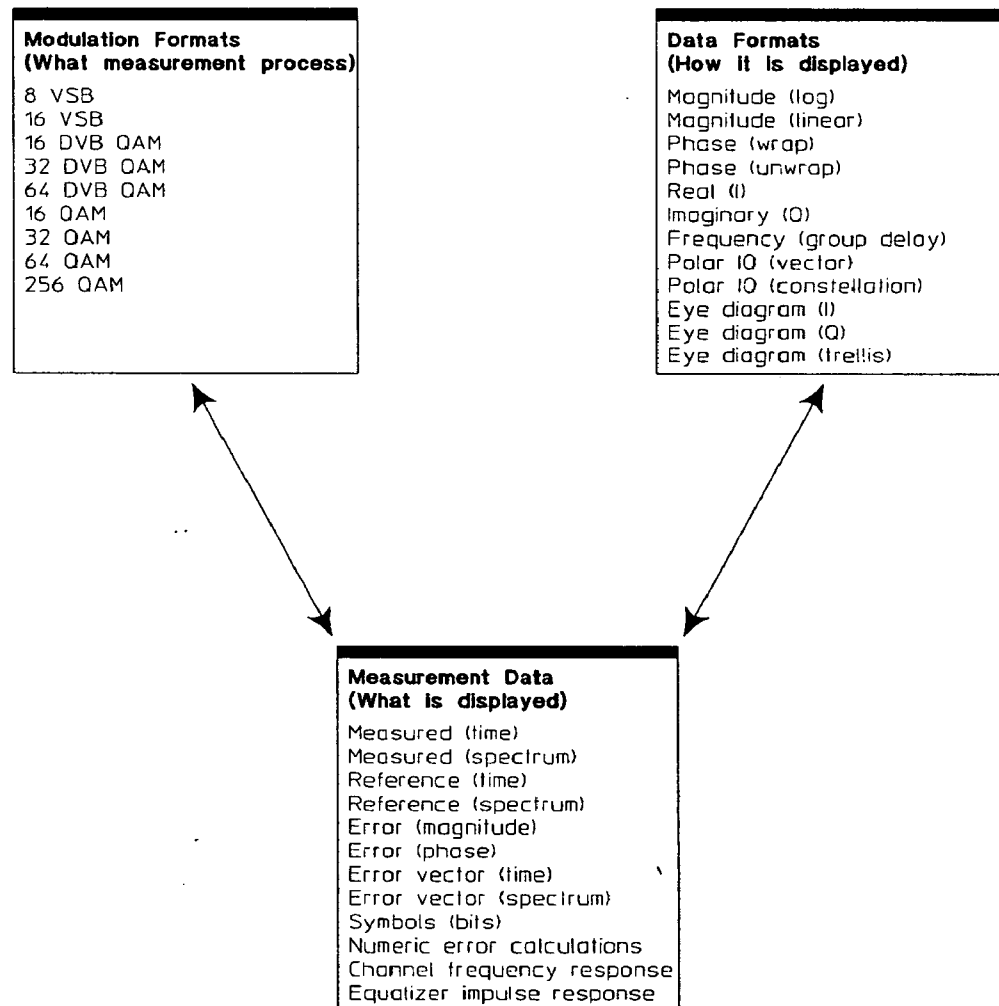

Carrier locking (all except VSB)

For QAM signals, the analyzer's center frequency must be close to the transmitted carrier frequency to achieve carrier lock. The required proximity of the center frequency to the carrier frequency varies depending on the signal type, symbol rate, and system noise. If symbol locking appears poor, you may achieve better carrier locking by observing the "Freq Err" value in the symbol table of any successfully locked measurement and adding that amount to the center frequency.

To obtain reliable carrier locking, the difference between the analyzer's center frequency and carrier frequency should be within 3% of the symbol rate for 16 and 32 QAM. For 64 and 256 QAM, the difference should be within 1% and 0.2%:

$$16 \text{ or } 32 \text{ QAM/DVB QAM: } (\text{center frequency}) - (\text{carrier frequency}) \leq \pm .03 (\text{symbol rate})$$

$$64 \text{ QAM/DVB QAM: } (\text{center frequency}) - (\text{carrier frequency}) \leq \pm .01 (\text{symbol rate})$$

$$256 \text{ QAM/DVB QAM: } (\text{center frequency}) - (\text{carrier frequency}) \leq \pm .002 (\text{symbol rate})$$

For QAM signals, the result length also affects the analyzer's ability to achieve reliable carrier lock, as shown in the following table. Result lengths less than those shown may result in unreliable carrier lock. Optimal carrier locking occurs when the result length is 1000 or greater.

If the modulation type is:	The minimum result length for reliable carrier lock is:
16 QAM or 16 DVB QAM	50 symbols
32 QAM or 32 DVB QAM	75 symbols
64 QAM or 64 DVB QAM	150 symbols
256 QAM	400 symbols

The following may also affect carrier locking:

- A frequency span that is too narrow.
- An incorrect range setting.
- Using the wrong measured or reference filter.

Carrier locking and pilot search: VSB

The same parameters that affect carrier locking for QAM signals also affect carrier locking for VSB signals. For VSB signals, the analyzer must also find the pilot signal to achieve carrier lock.

When you start a VSB measurement, the analyzer displays **SEARCHING FOR PILOT**. This message appears for a fixed amount of time while the analyzer searches for the pilot signal. The measurement begins when the pilot search ends (when the **SEARCHING FOR PILOT** message disappears).

If your VSB signal uses a high-side pilot, you must configure the analyzer to demodulate a high-side pilot by selecting the Video Demodulation instrument mode and pressing [**Instrument Mode**], [demodulation setup], [demod format], [freq spectrum **mirror**]. If you don't do this, the analyzer cannot find the pilot signal and cannot lock to your signal.

If the analyzer cannot lock to your signal, it displays **CARRIER LOCK?**. There are several conditions that may cause loss of carrier lock, one of which is an unsuccessful pilot search. If carrier lock is not obtained after several measurements, the analyzer assumes the pilot search failed and repeats the pilot search.

CARRIER LOCK? may appear even when the data appears to be locked. If this occurs, the results may be inaccurate. Normally, this condition clears in a few measurements as the instrument obtains better estimates of the carrier frequency.

The following paragraphs describe other conditions that may cause loss of carrier lock. The analyzer always assumes pilot search failed if there are carrier lock problems, even if the cause is one of the conditions below.

Like QAM signals, the analyzer's center frequency must be close to the transmitted carrier frequency to achieve carrier lock for VSB signals. The following formulas show you how to calculate the ideal center frequency. Use the formula for *low-side pilot* if your pilot is on the left (low) side of your spectrum; use *high-side pilot* if your pilot is on the right (high) side of your spectrum.

$$\text{Center Frequency (LOW SIDE PILOT)} = \frac{\text{Symbol Rate}}{4} + (\text{Pilot Frequency})$$

$$\text{Center Frequency (HIGH SIDE PILOT)} = (\text{Pilot Frequency}) - \frac{\text{Symbol Rate}}{4}$$

Hint

The "Using Video Demodulation" chapter contains a task that shows you how to use the analyzer's frequency counter to measure your pilot frequency.

The result length also affects the analyzer's carrier locking. For VSB measurements, the result length should be at least 800 symbols. Smaller result lengths may cause unreliable carrier locking.

Video Demodulation Concepts

The following may also cause loss of carrier lock:

- A frequency span that is too narrow.
- An incorrect range setting.
- Using [freq spectrum **normal**] when you should be using [freq spectrum **mirror**].
- A pilot that is not in phase with the transmitted data. You may be able to compensate for pilot-phase problems by using [clock adjust] to change when the analyzer samples the I/Q trajectory (press [**Instrument Mode**], [demodulation setup], [more], [clock adjust]).

Input Range

The input range must be set correctly to obtain accurate measurements. Input ranges that are too low overload the analyzer's ADC. Input ranges that are too high increase noise, which increases errors reported in error parameters, such as EVM.

To select the optimum input range when using the RF section (2-2650 MHz) receiver, press [**Range**], [ch1 range] and decrease the range (using the down-arrow key) until *OVI* appears in the active trace. Then increase the range one step at a time (by pressing the up-arrow key) until *OVI* disappears.

To select the optimum input range when using the RF section (0-10 MHz) receiver or the IF section (0-10 MHz) receiver, press [**Range**], [ch1 range] and decrease the range (using the down-arrow key) until the Channel 1 Over and Half LEDs turn on. Then increase the range one step at a time (by pressing the up-arrow key) until the Over LED turns off.

I-Q measured signal

The IQ measured signal is the result of resampling the data to an integer number of points per symbol and applying system gain normalization, carrier locking, and filtering to the incoming signal. The filtering is root-raised cosine with a user-adjustable alpha. For QAM measurements, the analyzer also applies I/Q origin offset compensation (similar to pilot removal for 8 VSB and 16 VSB). I/Q origin offset compensation is not applied to DVB QAM measurements.

I-Q reference signal

A powerful analysis technique involves comparing a demodulated signal with an ideal signal generated from detected bits. The analyzer detects bits from the measured IQ signal and reconstructs a sequence of ideal I and Q states. These are then treated as ideal impulses and are baseband filtered using a raised cosine filter selected by the user. The resultant IQ reference can be overlaid or compared side-by-side with the IQ measured signal.

Parameter interactions

Changing one parameter may necessitate changes in other parameters to achieve the desired measurement. The following topics may help you optimize your measurements and explain the reasons for changes made automatically by the analyzer.

Data size considerations

Maximum data size for measured and reference IQ data is generally determined by max time pts⁺⁺ which is user selectable, 64-4096. A given measurement will generally use all available memory as defined by max time pts:

$$\text{max time pts} \geq \text{result length} \times \text{points/symbol}$$

Resolution bandwidth

Resolution bandwidth in video demodulation is determined automatically by the analyzer, and cannot be set independently. Resolution bandwidth is determined by the time record length in the same manner as in Vector mode (see Fundamental Measurement Interactions):

$$RBW = WBW/T$$

where RBW = resolution bandwidth
T = time record length
WBW = window bandwidth

However, in Video Demodulation the time record length is determined as follows:

$$T \approx \text{Result Length (in symbols)}/\text{Symbol Rate}$$

++ See [max time pts] under [System Utility], [memory usage], [configure meas memory].

Span considerations

When selecting a frequency span, select the narrowest span that includes all of your signal components (select a span that is larger than the bandwidth of your signal). If you select a span that is too narrow, your measurement may have excessive errors or the analyzer may lose carrier lock. If you select a span that is too wide, your measurement may be affected by excessive noise and slower speed. You may want to select the Vector instrument mode and set the span while viewing the spectrum of your signal.

The analyzer displays a warning message if the frequency span is less than the symbol rate for QAM and DVB QAM formats, and less than half the symbol rate for VSB formats. If you see this warning message, increase the frequency span until it includes all components of your signal.

When using video demodulation, the symbol rate determines the maximum frequency span that you can select, as follows:

$$\text{Maximum Span (VSB)} = 20 \frac{(\text{SymbolRate})}{2.56}$$

$$\text{Maximum Span (All Other Formats)} = 20 \frac{(\text{SymbolRate})}{1.28}$$

These formulas can be rewritten to obtain the maximum-span-to-symbol-rate ratio. These ratios are fixed and cannot be changed.

$$\text{VSB: } \frac{\text{Maximum Span}}{\text{Symbol Rate}} = \frac{20}{2.56} \quad \text{OR} \quad \frac{\text{Maximum Span}}{\text{Symbol Rate}} = 7.8125$$

$$\text{All Other Formats: } \frac{\text{Maximum Span}}{\text{Symbol Rate}} = \frac{20}{1.28} \quad \text{OR} \quad \frac{\text{Maximum Span}}{\text{Symbol Rate}} = 15.625$$

For VSB measurements, you must use arbitrary spans; you cannot use cardinal spans (cardinal spans are spans that are powers of two, such as 2.5 MHz, 5 MHz, and 10 MHz). The analyzer displays an error message if you select a cardinal span when using the VSB demodulation format.

You may notice that the frequency span for digitally demodulated spectrums (the IQ measured spectrum, IQ reference spectrum, and error vector spectrum) is different than that set with the [span] softkey. The reason is that the digital demodulation process derives its own frequency span and sample rate, as follows:

$$\begin{aligned} \text{Demod Sample Rate} &= (\text{symbol rate}) \times (\text{points-per-symbol}) \\ \text{Demod Span} &= (\text{Demod Sample Rate})/1.28 \end{aligned}$$

When viewing digitally demodulated spectrums, aliasing may occur if the frequency span is too large. The aliasing does not affect the accuracy of the demodulation, only the validity of the spectral displays. The analyzer displays DATA? if it suspects aliasing in digitally demodulated spectrums. To prevent aliasing, be sure that:

$$\text{Frequency Span} \leq \frac{\text{Symbol Rate} \times (\text{points-per-symbol})}{1.28}$$

where: *Frequency span* is set by pressing [**Frequency**] [span].

symbol rate is set by pressing [**Instrument Mode**], [demodulation setup], [symbol rate].

points-per-symbol is set by pressing [**Time**], [points/symbol].

Display limitations

Points per symbol affects all displayed results by controlling result resolution but is not coupled to span. More points per symbol improves the resolution of the vector diagram, but there is still only one point at the symbol clock.

$$(\text{number of time points}) = (\text{result length}) \times (\text{points-per-symbol})$$

Result length takes precedence over points per symbol—if you try to set points per symbol such that the number of time points would exceed the memory size⁺⁺, an error indicates that the requested number of points per symbol cannot be set. In this case, you may choose to reduce the result length to allow an increased number of points per symbol. Conversely, if you increase result length such that the number of time points exceeds the memory limit, points per symbol automatically decreases to allow the result length to increase.

++ See [max time pts] under [**System Utility**], [memory usage], [configure meas memory].

Feature Availability in Video Demodulation

Most features that are available with other instrument modes are also available with video demodulation with the following exceptions:

- Time gating is not available
- Averaging is not available for any trace data in video demodulation but may be applied to numeric error data in the error table. Three types of averaging are available:
 - rms (video)—computes an rms average of each rms error update in the table
 - rms exponential—is like rms (video) except that averaging continues past the average count with an exponential weighting
 - continuous peak hold—keeps track of the peak rms error of each update in the table

Special considerations for sync search

Synchronization words (or patterns) are often used to resolve carrier phase ambiguity on non-differential modulation formats. It is important to realize that synchronization words are optional and are not necessary in order to achieve carrier locking.

Note

You cannot use sync search for VSB measurements. The [sync search on/off] softkey (under the [Time] hardkey) is ghosted (inactive) if VSB is selected.

Sync search lets you use a synchronization pattern to isolate a portion of your signal for display and analysis. The analyzer searches through demodulated data to find your sync pattern, and then uses the [result length] to determine how much data to display, and the [offset] to display data relative to the sync pattern.

Note

The sync pattern must be a multiple of the number of bits-per-symbol. For example, if the number of bits-per-symbol is 4 (as with 16 QAM), the number of bits in the sync pattern must be a multiple of four. Sync search lets you specify any number of bits for the sync pattern, however, bits that aren't a multiple of the bits-per-symbol are truncated. In this example, if you entered 6 bits for the sync pattern, sync search would only use the first four bits.

Triggering determines when the analyzer starts demodulating data and search length determines when the analyzer stops demodulating data. Sync search locates only the first match and ignores any subsequent matches within the search length. The sync pattern and the offset must fit within the search length.

You may use sync search with or without pulse search, although many measurements require both features.

See online help for the following softkeys for additional information (all softkeys are under the [Time] hardkey):

- [sync search]
- [search length]
- [sync setup], [pattern]
- [sync setup], [offset]

Special considerations for pulsed signals

You can use pulse search to demodulate pulsed (burst) transmissions. Pulsed transmissions are generated by on/off carriers such as those used in mobile units.

Note

You cannot use pulse search for VSB measurements. The [pulse search on/off] softkey (under the [Time] hardkey) is ghosted (inactive) if VSB is selected.

Speed and resolution considerations

Maximizing speed - measurement and display

- Use fewer points per symbol
- Use fewer symbols
- Decrease span

Maximizing resolution

- Use more points per symbol
- Increase max time points⁺⁺

⁺⁺ This parameter is under [System Utility] (memory usage) (config meas memory). See the online help on this key for more information on this topic.

Filtering

The IQ measured signal is always passed through a root-raised cosine filter with the selected alpha.

Mirrored Spectrums

The HP 89441V provides a feature that lets you configure the analyzer's demodulator to conjugate the complex time-domain waveform. This has the effect of flipping the spectrum around the analyzer's center frequency. To enable this feature, select the Video Demodulation instrument mode, then press **[Instrument Mode]**, **[demodulation setup]**, **[demod format]**, **[freq spectrum mirror]**.

This feature is often used with VSB measurements that use a high-side pilot. For VSB signals, the pilot must be on the low-side of the spectrum to achieve carrier lock. For details, see "Carrier locking and pilot search: VSB" earlier in this chapter.

This feature may also be used with QAM measurements to obtain the correct data patterns.

RF receiver and 8 MHz spans

HP 89441V lets you extend the maximum frequency span of the RF receiver from 7 MHz to 8 MHz. Press [**Instrument Mode**] [receiver] [RF (2-1800 MHz)] to display the *normal* (7 MHz) and *wide* (8 MHz) softkey menu. Press [RF (2-1800 MHz) **normal**] to select the RF section with a maximum frequency span of 7 MHz; press [RF (2-1800 MHz) **wide**] to extend the maximum frequency span to 8 MHz.

Remember that, in two-channel analyzers, channel 1 determines the frequency span of channel 2. Therefore, selecting wide (8 MHz) also extends the frequency span of channel 2 to 8 MHz (channel 2 is always baseband, so the frequency span is 0 to 8 MHz).

Normal (7 MHz) provides the best specifications: for example, improved noise performance.

Index

!

2-channels
 video demod 1-19

A

A,B,C,D LEDs HT
 accessories vi
 adaptive equalization
 See equalization filter
 aliasing
 video demod 10-11
 alpha entry, using HT
 alpha, setting HT
 amplitude droop (in symbol table) HT
 analyzers
 types of 7-4
 applications softkey HT
 arm
 See external arm
 arrow keys HT
 assistance (by phone) 2-i
 atv 16 HT
 atv 8 HT
 AUI connector HT
 auto cal on/off softkey HT
 auto sweep, selecting HT
 auto zero calibration
 See Also calibration
 autorange softkeys HT
 autorange, using HT
 autostate file HT
 creating HT
 recalling HT
 average power HT
 averaging HT
 about averaging HT
 auto correlation traces HT
 available averaging functions HT
 cross correlation traces HT
 cross spectrum traces HT
 exponential averaging HT

fast averaging HT
 frequency response traces HT
 instantaneous-spectrum traces HT
 long averages and calibration HT
 overlap processing HT
 pausing HT
 peak-hold averaging HT
 repeat averaging HT
 rms averaging HT
 rms exponential averaging HT
 selecting an averaging function HT
 selecting the number of averages HT
 single-stepping HT
 spectrum traces HT
 time averaging HT
 time exponential-averaging HT
 video demodulation 10-14
 AYH (video modulation analysis) HT
 AYJ (adaptive equalization) 2-1

B

band power measurements 3-2, HT
 band-selectable measurements 8-3
 See Also zoom measurements
 bandwidth
 See information bandwidth
 See noise equivalent bandwidth
 See resolution bandwidth
 See window bandwidth
 bandwidth coupling 8-4
 baseband measurements 8-3, HT
 baseband signals
 video demod 1-19
 BASIC HT
 about HP instrument BASIC HT
 available utilities HT
 creating a program with keystrokes HT
 debugging a program HT
 deleting a function HT
 deleting a program HT
 deleting a subprogram HT

Index

- deleting multiple functions HT
- deleting multiple subprograms HT
- displaying a program HT
- displaying graphics HT
- editing a program HT
- executing a single program line HT
- indenting nested programs HT
- memory allocations HT
- printing a program HT
- program error messages HT
- program variables HT
- re-saving programs HT
- recalling programs HT
- renumbering a program HT
- resetting a program HT
- running a program HT
- saving programs HT
- securing a program HT
- specifying columns HT
- stack space, auto allocation HT
- stack space, manual allocation HT
- stopping a program HT
- beeper on/off softkey HT
- bins
 - See frequency points
- bins, defined HT
- block diagrams HT
 - ch1 + j*ch2 receiver HT
 - connectors, front panel HT
 - connectors, rear panel HT
 - FFT overview HT
 - general 7-11
 - HP IBASIC memory HT
 - instantaneous spectrums HT
 - main memory HT
 - measurement data HT
 - measurement memory HT
 - scalar 6-3, HT
 - source block diagram HT
 - time capture HT
 - traces HT
 - vector 6-5, HT
 - video demodulation 10-3
- block size
 - See time record size
- C**
- C/N (carrier-to-noise) HT
- C/No (carrier-to-noise-density) HT
- CAL?, definition of HT
- calibration HT
 - about calibration HT
 - adjusting calibration data HT
 - auto zero calibration HT
 - auto zero calibration, single HT
 - performing a single calibration HT
 - saving calibration data HT
 - time-domain calibration HT
- capture
 - See time capture
- carrier frequency error (in symbol table) HT
- carrier lock? HT
- carrier locking
 - video demod 10-8
- center frequency HT
 - setting center frequency HT
 - setting with the marker HT
 - signal tracking HT
- ch1 + j*ch2 receiver HT
- changing numeric parameters HT
- channel
 - optional IF input v
- channel 1
 - See input channels
- channel 1 and 2 connectors HT
- channel 2
 - See input channels
- clear source trip softkey HT
- coherence HT
- color index softkey HT
- color, adjusting HT
- connector, front panel connectors HT
- connectors, rear panel connectors HT
- constellation diagram, example 1-14
- constellation diagram, using HT
- continuing a measurement HT
- continuous sweep, selecting HT
- coordinates, trace
 - See Also traces
- copying files between 3.5 inch diskettes HT
- correlation HT
 - auto correlation HT
 - cross correlation softkey HT
 - cross-correlation, math function HT
- coupling
 - bandwidth 8-4
- cross spectrum measurements HT
- CW (fixed sine) softkey HT

D

- data comment header HT
- data format hardkey HT
- data registers HT
 - about data registers HT
 - displaying data-register contents HT
 - removing HT
- DATA?, definition of HT
- date, changing HT
- dc measurements 8-9
- dc offset softkey (source) HT
- dc offset, compensation HT
- dc response 8-9
- decibels HT
- demodulation, video HT
 - about video demodulation HT
 - block diagram 10-3
 - capabilities 10-2
 - carrier frequency error (in symbol table) HT
 - carrier lock and result length HT
 - carrier locking 10-8
 - center frequency, setting 1-4
 - constellation diagram HT
 - DVB QAM 16/32/64 HT
 - DVB QAM state definitions HT
 - DVB QAM, example 1-12
 - error-vector magnitude (in symbol table) HT
 - eye diagram HT
 - filtering HT
 - formatting and displaying 10-7
 - formatting displays 1-14
 - gating 9-5
 - hexadecimal, in symbol table HT
 - I/Q measured, displaying HT
 - I/Q origin offset (in symbol table) HT
 - ideal states HT
 - magnitude error HT
 - maximum number of time points, setting HT
 - mirrored spectrums 10-17, HT
 - normalization HT
 - overview 6-6
 - phase error (in symbol table) HT
 - points-per-symbol, setting HT
 - pulse modulation HT
 - QAM 16/32/64/256 HT
 - range, setting 10-10
 - setup 1-2
 - SNR HT
 - standard setups, example HT
 - state definitions, defining HT
 - state definitions, displaying HT
 - symbol clock, adjusting HT
 - symbol locking 10-8
 - symbol rate, setting HT
 - sync patterns, using pre-defined patterns HT
 - sync search 1-16
 - sync words, using HT
 - trellis diagram HT
 - troubleshooting HT
 - VSB 8/16 HT
- detection 8-12, HT
 - about detection HT
 - normal detector HT
 - positive peak detector HT
 - sample detector HT
- diagnostics softkey HT
- disk drive
 - flexible disks for vii
- disk drives HT
 - about disk drives HT
 - comparison HT
 - copying files HT
 - deleting files HT
 - displaying contents of HT
 - external disk drive HT
 - formatting HT
 - HP-IB address: external disk drive HT
 - internal disk drive HT
 - non-volatile RAM disk HT
 - packing a disk HT
 - renaming files HT
 - selecting a default disk HT
 - using disk specifiers HT
 - volatile RAM disk HT
 - volatile RAM disk, removing HT
- display HT
 - adjusting the color HT
 - allocating portion for programs HT
 - blanking HT
 - changing colors HT
 - indicators HT
 - See Also traces
 - display group hardkeys HT
 - display points, defined HT
 - display resolution 8-11 - 8-12
 - display, digital 8-9
 - documentation HT
 - DVB 16 HT

Index

- DVB 32 HT
- DVB 64 HT
- DVB QAM HT
 - block diagram 10-4
- dynamic signal analyzers 7-6
- E**
- entry group hardkeys HT
- equalization filter 2-1, HT
 - about the equalization filter HT
- frequency response HT
 - impulse response HT
- equivalent noise bandwidth HT
- error & status messages HT
- error-vector magnitude (in symbol table) HT
- error-vector magnitude, displaying EVM trace HT
- EXT ARM connector HT
- EXT REF IN connector HT
- EXT REF OUT connector HT
- EXT TRIGGER connector HT
- external arm HT
 - about external arm HT
 - trigger, using with external arm HT
 - turning on/off HT
- external calibration softkey HT
- EXTERNAL MONITOR connector HT
- external receiver
 - See Also receiver
- external softkey HT
- external trigger, overview HT
- eye diagram, example 1-14
- eye diagram, using HT
- F**
- fault log, displaying HT
- FFT 7-6
 - properties of 7-7
 - See Also spectrum analyzers
- FFT, overview & terminology HT
- FILLING TIME RECORD, definition of HT
- filters
 - IF 8-18
 - video 8-3
- firmware version, displaying HT
- flexible disks vii
- fonts HT
- fourier transform 7-7
- French softkey HT
- freq counter softkey HT
- frequency HT
 - about frequency parameters HT
 - center frequency HT
 - frequency counter HT
 - frequency span HT
 - manual frequency, setting HT
 - signal tracking HT
 - span, extending to 8 MHz HT
 - start frequency HT
 - step size HT
 - stop frequency HT
 - using markers to set step size HT
- frequency domain overview 7-2
- frequency error (in symbol table) HT
- frequency points 8-5, HT
 - about frequency points HT
 - and display 8-12
 - memory allocation HT
 - setting the number of HT
- frequency resolution 8-11
- frequency response measurements HT
- frequency span
 - and display 8-5
 - and information bandwidth 8-3
 - and resolution bandwidth 8-14, 8-19
 - video demodulation 10-12
- front panel tour HT
- FTP (File Transfer Protocol) HT
- FTP, and LAN 4-10
- full span softkey HT
- G**
- gate length softkey HT
- gate time-record HT
 - displaying HT
 - gate delay HT
 - gate time HT
 - gate-delay step size HT
 - setting the length of HT
 - turning on/off HT
- GATHERING DATA, definition of HT
- gating
 - description 9-2
- German softkey HT
- ghosted softkeys HT
- grids HT
 - 1 grid HT
 - 2 grids HT
 - 4 grids HT
 - hiding HT
- group delay softkey HT

H

half LED HT
 description of HT
 using to set the range HT
 hardkeys, defined HT
 help (by phone) 2-i
 Help hardkey HT
 hold scale softkey HT
 HP-GL (Hewlett-Packard graphics language) HT
 HP-IB HT
 about the HP-IB HT
 addressable only HT
 HP-IB address: analyzer HT
 HP-IB address: external devices HT
 HP-IB address: external disk drive HT
 HP-IB address: external receiver HT
 HP-IB address: plotter HT
 HP-IB address: printer HT
 HP-IB controllers HT
 keys that have HP-IB commands HT
 LAN use 4-6
 system controller HT

I

I-BASIC, instrument BASIC
 See BASIC
 ideal state softkey HT
 IF bandwidth, external receiver HT
 IF center frequency, external receiver HT
 IF section (0-10 mhz) softkey HT
 IF trigger
 See trigger
 indent softkey HT
 indicators, display HT
 INF, meaning of HT
 information bandwidth 8-3, 8-10
 input channels HT
 about input channels HT
 channel 2 with RF section HT
 clearing input overloads HT
 compensating for dc offset HT
 compensating for gain & delay HT
 connections HT
 coupling: ac or dc HT
 dBm calculations HT
 disabling HT
 disabling the anti-alias filter HT
 input impedance HT
 input-state table HT

input hardkey HT
 input section (ch1 + j*ch2) softkey HT
 installing options HT
 instantaneous spectrum, displaying HT
 instrument mode hardkey HT
 IQ measured signal 10-10
 IQ reference signal 10-10
 Italian softkey HT

K

keyboard HT
 about the keyboard HT
 keyboard connector HT
 keyboard type HT
 knob HT
 about the knob HT
 changing the operation of HT

L

LAN
 about the advanced LAN (option UG7) HT
 about the lan HT
 activating 4-5
 addressing 4-4
 and FTP 4-10
 connectors, descriptions HT
 controlling the analyzer via the lan HT
 ethernet address, displaying HT
 FTP (File Transfer Protocol), using HT
 gateway address, setting HT
 HP-IB with 4-6
 interface, connecting 4-1
 IP address, setting HT
 port, configuring HT
 ports, activating HT
 ports, selecting HT
 subnet mask, setting HT
 Telnet, about HT
 X-Windows with 4-7
 X11 display, configuring HT
 X11 display, controlling the analyzer with HT
 X11 display, setting the update rate HT
 X11 IP address, setting HT
 LAN (local area network) HT
 leakage 8-6
 learning products (manuals) HT
 LEDs: front panel HT
 level softkey HT
 linear averaging
 See time averaging

Index

- lines
 - See frequency points
- lines, defined HT
- listen LED HT
- LO feedthrough
 - See zero response
- loading files
 - See recalling
- Local Area Network
 - See LAN
- local oscillator 7-12
- M**
- magnitude log(dB)/linear softkey HT
- main length softkey HT
- main time vs. gate time HT
- main time-record
 - displaying HT
 - length equal to gate length HT
 - main length HT
 - main time HT
 - setting the length of HT
 - See Also time record
- manual sweep 8-13
- manual sweep, selecting HT
- manuals, for this product HT
- Marker Cnt, meaning of HT
- marker group hardkeys HT
- Marker Man, meaning of HT
- marker readout HT
- Marker/Entry LED HT
- markers HT
 - about markers HT
 - band power HT
 - band power, rms square-root of HT
 - carrier-to-noise HT
 - carrier-to-noise-density HT
 - frequency counter HT
 - marker into center frequency HT
 - marker into reference level HT
 - marker into span HT
 - marker into start frequency HT
 - marker into stop frequency HT
 - multiple traces HT
 - offset marker, zeroing HT
 - offset markers, repositioning HT
 - offset markers, using HT
 - peak tracking HT
 - polar display markers HT
 - repositioning markers HT
 - search functions HT
 - trace annotation HT
 - turning on markers HT
 - using for numeric entry HT
 - using to set frequency step size HT
 - using to update frequency values HT
 - x-axis, scaling with markers HT
- math HT
 - about math HT
 - cross-correlation math function HT
 - defining a math constant HT
 - displaying math functions HT
 - displaying results HT
 - math constants, overview HT
 - math function operands HT
 - math functions HT
 - memory for math-buffers HT
 - recalling math functions HT
 - saving math functions HT
- MAU connector HT
- measured signal
 - video demod 10-10
- measurement calculations, disabling HT
- measurement data, about HT
- MEASUREMENT Group hardkeys HT
- measurement points, defined HT
- measurement resolution 8-11
- measurement speed, enhancing HT
- measurement state HT
 - recalling HT
 - saving HT
- measurement time 8-2, 8-10, 8-17
- measurements HT
 - continuing HT
 - displaying the measurement-state table HT
 - pausing HT
 - single-stepping HT
 - starting HT
- memory HT
 - about memory H-1
 - capture RAM HT
 - erasing HT
 - for applications HT
 - for frequency points HT
 - for temporary math buffers HT
- memory limitations 8-19
- menu HT
- mirror freq on/off softkey HT
- mirrored spectrums 10-17
- Mkr Val HT

N

NAN, meaning of HT
 narrowband measurements 7-8
 Network, Local Area
 See LAN
 NO DATA, definition of HT
 noise equivalent bandwidth 8-18
 non-volatile RAM disk
 See disk drives
 normalization HT
 numeric entry softkeys HT

O

offset
 video demod 1-16
 offset marker
 See markers
 online help
 See Help hardkey
 options, installing HT
 options, temporary HT
 output filter on/off softkey HT
 output z softkey (source) HT
 OV1 or OV2, definition of HT
 OVEN REF OUT connector HT
 over LED HT
 description of HT
 using to set the range HT
 overlap processing HT

P

packing a disk HT
 PARALLEL PORT HT
 pausing a measurement HT
 PCL (HP-GL) (PCL embedded HP-GL)
 HT
 PCL (printer control language) HT
 peak power HT
 peak search HT
 peak to average power 1-8, HT
 peak track softkey HT
 peak-hold averaging
 See Also averaging
 performance test softkey HT
 phase, displaying HT
 phone assistance 2-i
 plotting HT
 aborting HT
 about plotting HT
 changing plotter pen assignments HT
 data and file formats HT

date and time HT
 default pen assignments HT
 output to file HT
 plot speed HT
 selecting an output device HT
 selecting display items HT
 setting P1/P2 HT
 setting the HP-IB address HT
 specifying line types HT
 starting HT

points

 See frequency points
 points, defined HT
 points-per-symbol, setting HT
 polar display, using HT
 post-trigger delay HT
 power HT
 average HT
 band power 3-2, HT
 band power, rms square-root of HT
 carrier-to-noise HT
 carrier-to-noise-density HT
 peak HT
 peak to average HT
 power ratio HT
 statistical power measurements HT
 pre-trigger delay HT
 preset hardkey HT
 printing HT

 aborting HT
 about printing HT
 data and file formats HT
 date and time HT
 online help, printing HT
 output to file HT
 selecting an output device HT
 selecting display items HT
 setting the HP-IB address HT
 starting HT
 PROBE POWER connectors HT
 problems, video demodulation HT
 PSD measurements HT
 pulse search
 in video demodulation 10-16
 pulsed signals, demodulating 10-16

Q

QAM
 block diagram, video demod 10-4
 QAM 16/32 softkey HT
 QAM 16/32/64/256 softkey HT

Index

R

RAM

See memory

RAM disk

See disk drives

random noise softkey HT

range HT

autoranging HT

setting optimum range HT

single ranging HT

tracking the reference level HT

range hardkey HT

RBW

See resolution bandwidth

rear panel tour HT

recalling HT

about recalling HT

autostate file HT

BASIC programs HT

capture-buffer contents HT

math functions HT

measurement state HT

trace HT

receiver HT

about receivers HT

HP-IB address: external receiver HT

using an external receiver HT

receiver softkey HT

REF, definition of HT

reference level

See reference line

reference line HT

displaying HT

examples of HT

position of HT

setting reference level HT

setting with the marker HT

tracking the range HT

Remote LED HT

REMOTE OPERATION group

hardkeys HT

resolution

display 8-12

frequency 8-11

measurement 8-5

resolution bandwidth HT

about resolution bandwidth HT

and gating 9-5

See Also bandwidth coupling

coupling to frequency span HT

effect on noise 8-2

entering arbitrary values HT

interaction with other parameters HT

scalar limitations 8-11

setting the resolution bandwidth HT

vector limitations 8-18

video demod 10-11

result length

video demod 1-16

result length softkey HT

rms averaging

See averaging

RPG

See knob

RS232

See serial port

S

sample frequency

See sample rate

sample rate 8-14

video demodulation 10-12

samples, defined HT

saving HT

about saving HT

autostate file HT

calibration trace HT

capture buffer contents HT

math functions HT

measurement state HT

re-saving BASIC programs HT

saving BASIC programs HT

traces HT

scalar measurements HT

about scalar mode HT

block diagram HT

block diagrams 6-3

limitations 8-11

overview 6-2

scale at markers softkey HT

scaling HT

auto scaling HT

x-axis HT

x-axis scaling: linear vs. log HT

y-axis scaling HT

scan time

See sweep time

search length HT

video demod 1-16

searching for pilot HT

self test HT

long confidence test HT

- quick confidence test HT
- self-test log HT
- serial 1/serial 2 connectors HT
- serial number, displaying HT
- serial number, location HT
- serial port, configuring & cabling HT
- serial x setup softkey HT
- service assistance (by phone) 2-i
- shifted functions HT
- signal track softkey HT
- signal tracking HT
- sine freq softkey HT
- single measurements, running HT
- single range softkeys HT
- single ranging HT
- single sweep, selecting HT
- SNR, video demodulation HT
- softkeys HT
 - about softkeys HT
 - bracketed softkeys HT
 - numeric entry HT
 - softkeys that toggle HT
- source HT
 - about the source HT
 - amplitude, setting HT
 - available source outputs HT
 - connections HT
 - CW (fixed sine) output HT
 - displaying the source-state table HT
 - external signals, using as input to source HT
 - optional RF v
 - output filter, disabling HT
 - output impedance & dBm units HT
 - output impedance, setting HT
 - output protection, clearing HT
 - random noise output HT
 - sine frequency, setting HT
 - SOURCE LED HT
 - turning on and off HT
- source hardkey HT
- source type softkey HT
- span HT
 - arbitrary spans HT
 - cardinal spans HT
 - coupling to main length HT
 - maximum span HT
 - setting span HT
 - setting with the marker HT
 - video demodulation 10-12
- span softkey HT
- Spanish softkey HT
- spectrum analyzers
 - comparisons 7-9
 - types of 7-4
- spectrum measurements HT
- speed, enhancing HT
- SRQ LED HT
- start frequency HT
 - setting start frequency HT
 - setting with the marker HT
- starting a measurement HT
- state definitions HT
- stop frequency HT
 - setting stop frequency HT
 - setting with the marker HT
- suffix menus HT
- supplied accessories vi
- Swedish softkey HT
- sweep speed
 - See sweep time
- sweep time
 - described 8-10
 - See Also measurement time
- sweep, manual 8-13
- sweeping HT
 - about sweeping HT
 - auto sweep, selecting HT
 - continuous sweep, selecting HT
 - manual sweep, selecting HT
 - single sweep, selecting HT
- symbol clock, adjusting HT
- symbol rate 10-12
- symbol rate softkey HT
- SYNC NOT FOUND HT
- SYNC NOT FOUND, pulse search HT
- SYNC OUT connector HT
- sync pattern
 - video demod, creating, saving, recalling 1-18
 - video demod, user-defined 1-18
- sync search
 - example 1-16
 - video demod 10-15
- sync word
 - video demod 1-16
- SYSTEM Group hardkeys HT
- SYSTEM INTERCONNECT connector HT

Index

T

- talk LED HT
- telephone assistance 2-i
- Telnet, about HT
- testing
 - See self test
- ThinLan connector HT
- TIFF (tag-based file format)) HT
- time averaging 8-15
 - See averaging
- time capture HT
 - about time capture HT
 - calibration and time-capture HT
 - displaying capture information HT
 - displaying capture-buffer contents HT
 - recalling capture-buffer contents HT
 - saving capture-buffer contents HT
 - starting a time capture HT
 - time capture buffer HT
- time corrections HT
- time data 8-15
- time data softkey HT
- time domain overview 7-2
- time gating HT
 - about time gating HT
 - displaying gate time-record HT
 - gate delay HT
 - gate length HT
 - See gating
 - selecting a window HT
 - turning on/off HT
- time points, video demodulation HT
- time record 7-7, 8-16, HT
 - about the time record HT
 - applying a window HT
 - coupling to span HT
 - displaying gate time-record HT
 - displaying main time-record HT
 - effects of averaging HT
 - effects of demodulation HT
 - effects of span HT
 - FILLING TIME RECORD message HT
 - gate length HT
 - main length HT
 - real vs. complex data HT
- time record length
 - and memory 8-19
 - defined 8-16
 - limitations 8-19
- time record size
 - defined 8-16
- time resltn softkey HT
- time softkey (averaging) HT
- time, changing HT
- time-domain analysis HT
- time-domain data, displaying HT
- traces HT
 - about traces HT
 - activating multiple traces HT
 - adding a title HT
 - adding trace information HT
 - auto correlation HT
 - capture buffer contents HT
 - changing colors HT
 - coherence HT
 - coordinates HT
 - cross correlation HT
 - cross spectrum HT
 - data register contents HT
 - disabling measurement calculations HT
 - See Also display
 - displaying group delay HT
 - displaying linear magnitude HT
 - displaying log magnitude HT
 - displaying multiple traces HT
 - frequency response HT
 - See Also grids
 - hiding HT
 - imaginary part (imaginary data), displaying HT
 - instantaneous spectrum HT
 - marker annotation HT
 - math functions HT
 - modifying trace labels HT
 - overlying HT
 - phase, displaying HT
 - PSD HT
 - real part (real data), displaying HT
 - recalling HT
 - saving HT
 - scaling data, overview HT
 - selecting measurement data HT
 - spectrum HT
 - time-domain data HT
 - trace boxes HT
- trellis diagram, using HT
- trigger HT
 - about trigger HT
 - available trigger signals HT
 - delay HT
 - EXT TRIGGER LED HT
 - external arm, using with trigger HT

external trigger HT
 free run trigger HT
 HP-IB trigger HT
 IF channel trigger HT
 input channel trigger HT
 level HT
 slope HT
 source trigger HT
 trigger holdoff HT
 trigger LED HT
 trigger line HT
 trigger type softkey HT
 two-channels
 video demod 1-19

U

U.K. English softkey HT
 U.S. English softkey HT
 UFG (LAN and 4 MB memory option)
 HT
 UG7 (advanced LAN option) HT
 UNCAL, definition of HT
 units: x-axis HT
 units: y-axis HT

V

vector averaging
 See time averaging
 vector diagram, example 1-14
 vector measurements 7-8, HT
 block diagram HT
 block diagrams 6-5
 overview 6-4
 video averaging 8-3
 video demodulation
 See demodulation, video
 video filtering 8-3
 volatile RAM disk
 See disk drives
 VSB
 block diagram 10-6
 center frequency, setting 1-4
 demodulation 1-6
 VSB 8/16 softkey HT

W

window bandwidth
 defined 8-18
 values 8-18
 windows HT
 about windows HT
 comparison HT

equivalent noise bandwidth HT
 window bandwidth HT
 window functions 8-6
 window shapefactor HT
 windows for gate time record HT
 windows for main time record HT

X

x-axis scaling
 See scaling
 x-axis, scaling with markers HT
 X-Windows, LAN use 4-7
 X11 display, using
 See lan

Y

y-axis scaling
 See scaling

Z

zero padding 8-20
 zero response 8-9
 zero span measurements HT
 zoom measurements 7-8, 8-3, HT

Declaration of Conformity

According to ISO/IEC Guide 22 and EN 45014

Manufacturer's name: Hewlett-Packard Company
Manufacturer's address: Lake Stevens Instrument Division
8600 Soper Hill Road
Everett, Washington 98205-1298

declares, that the product

Product Name: Vector Signal Analyzer
Model Number: HP 89441A
Options: All

Similar Product(s):
Product Name: VSB/QAM Signal Analyzer
Model Number: HP 89441V
Options: All

*conforms to the following specifications, except as noted in the
Product Specifications:*

Safety: IEC 348/HD401

EMC: EN55011/CISPR 11: 1990/EN55011 (1991), Group1, Class A
EN50082-1/IEC 801-2: 1991/EN50082-1 (1992): 4 kV CD, 8 kV AD
EN50082-1/IEC 801-3: 1984/EN50082-1 (1992): 3 V/m
EN50082-1/IEC 801-4: 1988/EN50082-1 (1992): 1 kV

Supplementary Information:

The product herewith complies with the requirements of the Low Voltage Directive 73/23/EEC and the EMC Directive 89/336/EEC and bears the CE Mark.

Everett, Washington - October 1, 1997

Billy D Miracle

Billy Miracle, Quality Manager

Need Assistance?

If you need assistance, contact your nearest Hewlett-Packard Sales and Service Office listed in the HP Catalog, or contact your nearest regional office listed at the back of this guide. If you are contacting Hewlett-Packard about a problem with your analyzer, please provide the following information:

- Model number:
- Serial number:
- Options:
- Date the problem was first encountered:
- Circumstances in which the problem was encountered:
- Can you reproduce the problem?
- What effect does this problem have on you?

You may find the serial number and options from the front panel of your analyzer by executing the following:

Press **[System Utility]**, [more], [serial number].

Press **[System Utility]**, [options setup].

HP 89400-Series Documentation Roadmap

If you are thinking about...	And you want to...	Then read the analyzer's...
Unpacking and installing the analyzer	Install the analyzer, or do operation verification or performance verification tests	<i>Installation and Verification Guide</i>
Getting started	Make your first measurements with your new analyzer Review measurement concepts Learn what each key does	<i>Getting Started Guide</i> <i>Operator's Guide</i> Online Help (press the [Help] key)
Making measurements	Learn how to make typical measurements	<i>Getting Started Guide and Operator's Guide</i>
Creating automated measurements (To receive HP Instrument BASIC and HP Instrument BASIC manuals, order option 1C2)	Learn the HP Instrument BASIC interface Program with HP Instrument BASIC	<i>HP 89400-Series Using HP Instrument BASIC</i> <i>HP Instrument BASIC User's Handbook</i>
Remote operation	Learn about the HP-IB and SCPI Find specific HP-IB commands quickly Find HP-IB command details	<i>HP-IB Programmer's Guide</i> <i>HP 89400-Series HP-IB Commands: Quick Reference</i> <i>HP 89400-Series HP-IB Command Reference</i>
Using analyzer data with a PC application	Transfer analyzer data to or from a PC (Personal Computer) application Display analyzer data on a PC, or display PC data on the analyzer	<i>Standard Data Format Utilities: User's Guide</i>
Servicing the analyzer (To receive service information, order option 0B3)	Adjust, troubleshoot, or repair the analyzer	<i>Service Guide</i>

HP 89441V

dc to 2.65 GHz

VSB/QAM Signal Analyzer

Technical Data

Specifications describe warranted performance over the temperature range of 0 ° to 55 °C (except where noted) and include a 30-minute warm-up from ambient conditions, automatic calibrations enabled, auto-zero on, time domain calibration off, and anti-alias filter in, unless noted otherwise. Supplemental characteristics identified as "typical" or "characteristic," provide useful information by giving non-warranted performance parameters. Typical performance is applicable from 20 ° to 30 °C.

When enabled, automatic calibrations are periodically performed to compensate for the effects of temperature and time sensitivities. During the calibration, no signals >0 dBm should be connected to the front panel inputs.

Definitions

Baseband = dc to 10 MHz measurements.

Baseband time = Time-domain measurements selected by setting start frequency to exactly 0 Hz or choosing full span in 0 to 10 MHz measurements.

dBc = dB relative to input signal level.

dBfs = dB relative to full scale amplitude range setting. Full scale is approximately 2 dB below ADC overload.

FS or fs = Full scale; synonymous with amplitude range or input range.

RBW = Resolution bandwidth.

RF = 2 MHz to 2.65 GHz measurements.

Scalar mode = Measurements with only frequency-domain analysis available. Frequency spans up to 2648 MHz.

SNR = Signal to noise ratio.

Vector mode = Measurements with frequency- and time-domain capabilities. Frequency spans up to 10 MHz in baseband, and 8 MHz for RF analysis.

Zoom time = Time-domain measurements selected by setting frequency parameters using center frequency and span values.

Standard Features

Frequency

dc to 2.650 GHz
51 to 3201 points
Center frequency signal-tracking

Instrument modes

Scalar (frequency-domain only)
Vector (amplitude and phase information in frequency- and time-domain and also time-gating)

Sweep types

Continuous Manual
Single

Triggering

Free run External
Input channel External arm
IF channel Programmable polarity and level
HP-IB
Trigger holdoff Pre and post delay

Averaging

Video Peak hold
Video exponential Simultaneous display of instantaneous and average spectrum
Time
Time exponential

Source Types

CW
Random noise

Input

One channel
Second 10 MHz input channel (optional)
Auto-ranging (baseband only)
Overload indicators
50/75/1M Ω BNC (dc to 10 MHz)
50 Ω Type-N, 75 Ω with minimum-loss pad (2 MHz to 2650 MHz)

Resolution/window shapes

1-3-10 bandwidth steps
Arbitrary RBW
Windows: Flat-top (high amplitude accuracy), Gaussian-top (high dynamic range), Hanning (high frequency resolution), Uniform
Detectors: normal, positive peak, sample

Measurement data

Spectrum Time capture
PSD Frequency response, coherence, cross spectrum, and cross correlation (with second 10 MHz input channel)
Main time
Gate time
Math function
Data register
Auto correlation Instantaneous spectrum
Additional data formats for video demodulation

Data format

Log magnitude Imaginary part
Linear magnitude Group delay
Phase (wrap or unwrap) Log/linear x-axis
Real part

Trace math

Display

1, 2, or 4 grids
1 to 4 traces displayed (single or overlay)
Auto-scaling
Color (user definable)
User trace title and information
Graticule on/off
Data label blanking
X-axis scaling
Instrument/Measurement state displays
External monitor

Markers

Marker search: Peak, next peak, next peak right, next peak left, minimum
Marker to: Center frequency, reference level, start frequency, stop frequency
Offset markers
Couple markers between traces
Marker functions: Peak track, frequency counter, band power (frequency, time, or demodulation results) peak/average statistics

Memory and data-storage

Disk devices
Nonvolatile RAM disk (100 Kbyte)
Volatile RAM disk (up to 1 Mbyte)
90 mm (3.5-inch) 1.44 Mbyte flexible disk (HP LIF or MS-DOS[®] formats)
External HP-IB disk
Disk format and file delete, rename, and copy
Nonvolatile clock with time/date
Save/recall of: Trace data, instrument states, trace math functions, HP Instrument BASIC programs, time-capture buffers

Online help

Hard copy output

HP-IB/HPGL plotters
HP-IB/RS-232/parallel printers
Plot to file
Time stamp
Single-plot spooling

Interfaces

HP-IB (IEEE 488.1 and 488.2)
External reference in/out
External PC-style keyboard
Active probe power
RS-232 (one port)
Centronics
LAN and second HP-IB

Standard data format utilities

Optional features

HP Instrument BASIC (Option 1C2)
Advanced LAN support (Option UG7)

HP 89441V Technical Data

RF

Resolution bandwidth

Range 312.5 μ Hz to 3 MHz in 1, 3, 10 sequence or arbitrary user-definable bandwidth

Note: In scalar mode, the minimum resolution bandwidth is 312.5 μ Hz and the maximum resolution bandwidth is a function of span. In vector mode, the minimum resolution bandwidth is a function of span and the number of frequency points, and the maximum resolution bandwidth is a function of span only.

Window	Selectivity*	Passband flatness	Sideband level
Flat-top	2.45:1	+ 0, -0.01 dB	-95 dBc
Gaussian-top	4.0:1	+ 0, -0.68 dB	-125 dBc
Hanning	9.1:1	+ 0, -1.5 dB	-32 dBc
Uniform	716:1	+ 0, -4 dB	-13 dBc

* Shape factor or ratio of -60 dB to -3 dB bandwidths.

Amplitude

Input range	-50 dBm to + 25 dBm (5 dB steps)
Maximum safe input power	
Average continuous power	+ 25 dBm (300 mW)
DC voltage	25 V
A/D overload level (typical)	> 1.5 dB above range

Input port

Input channels	1
VSWR	
Range \geq -20 dBm	1.6:1 (12.7 dB return loss)
Range \leq -25 dBm	1.8:1 (11 dB return loss)
Impedance	50 Ω (75 Ω with minimum-loss pad Option 1D7)
Connector	Type-N

Amplitude accuracy

Accuracy specifications apply with flat-top window selected.

Amplitude accuracy is the sum of absolute full-scale accuracy and amplitude linearity.

Absolute full-scale accuracy (with signal level equal to range)

\geq -25 dBm range	20 ° - 30 °C \pm 1 dB (0.5 dB typical)	0 ° - 55 °C \pm 2 dB
\leq -30 dBm range	\pm 1.5 dB (0.5 dB typical)	\pm 3 dB

Amplitude linearity

0 to -30 dBfs	< 0.10 dB
-30 to -50 dBfs	< 0.15 dB
-50 to -70 dBfs	< 0.20 dB

In vector mode, relative level accuracy within a single span is the sum of vector mode frequency response and amplitude linearity.

Vector mode frequency response (relative to the center frequency) \pm 0.4 dB

Dynamic range

Dynamic range indicates the amplitude range that is free of erroneous signals within the measurement bandwidth.

Harmonic distortion (with a single full scale signal at the input)

\geq -25 dBm range	< -75 dBc
\leq -30 dBm range	< -54 dBc

Third-order intermodulation distortion (with two input tones at 6 dB below full scale and \geq 10 MHz)

General spurious (with input signal level equal to range and input frequency \leq 2650 MHz)

For spans \leq 1.5 MHz and for offset frequencies \leq 1.5 MHz from input signal	< 75 dBc
For all spans and offsets	< -70 dBc*
Residual responses (50 Ω input)	< -80 dBfs

Input noise density (50 Ω input, vector mode or scalar mode with sample detector)**

	20 ° - 30 °C	0 ° - 55 °C
\geq -25 dBm range	< -115 dBfs/Hz	< -112 dBfs/Hz
\leq -30 dBm range	< -110 dBfs/Hz	< -109 dBfs/Hz

Sensitivity**

-50 dBm range	< -160 dBm/Hz	< -159 dBm/Hz/Hz
---------------	---------------	------------------

* < -60 dBc for RF (2-2650 MHz)-wide

** Add 4 dB for RF (2-2650 MHz)-wide

Phase (vector mode)

Phase specifications apply with flat-top window selected.

Deviation from linear phase (relative to best fit line with peak signal level within 6 dB of full scale) ± 5 deg

Time (vector mode)

Time-sample resolution = $1/(k*\text{span}(\text{Hz}))$ [second]; where $k = 1.28$ for zoom time.

Main time length = (number of frequency points - 1) \div span (Hz) [second]; for resolution bandwidth in arbitrary and auto-coupled mode.

Amplitude accuracy (for a sine wave in the measurement passband, time-domain calibrations on, range ≥ -25 dBm)

20 ° - 30 °C $\pm 12\%$ full scale
($\pm 6\%$ typical)
0 ° - 55 °C $\pm 26\%$ full scale

Sample error rate for zoom time (typical)

Error threshold: 10^{-8} times/sample
5% full scale

Sample error rate reflects the probability of an error greater than the error threshold occurring in one time sample.

Trigger

Trigger types

Scalar mode Free run, HP-IB, external
(each measurement step requires a separate trigger)

Vector mode Free run, IF channel,
HP-IB, external

Pre-trigger delay range (see time specifications for sample resolution)

One channel 64 Ksamples (1 Msample with extended time capture, Option AY9)

Two channels (requires second 10 MHz input, Option AY7) 32 Ksamples (0.5 Msample with extended time capture, Option AY9)

Post-trigger delay range (see time specifications for sample resolution) 2 Gsample

Trigger holdoff

When enabled, each measurement requires two trigger events. The first event starts a holdoff timer. After the specified holdoff time, a subsequent trigger event will initiate a measurement.

Holdoff resolution 2.5 μ s
Holdoff range 2.5 μ s to 41 s

IF trigger (characteristics only)

Used to trigger only on in-band energy, where the trigger bandwidth is determined by the measurement span (rounded to the next higher $10^{7/2^n}$ [Hz]).

Amplitude resolution < 1 dB
Amplitude ranges +1 to -70 dBfs.
Useable range will become limited by the total integrated noise in the measurement span.

IF trigger hysteresis < 4 dB

External trigger (positive and negative slope)

Level accuracy ± 0.5 V
Range ± 5 V
Input impedance 10 k Ω (typical)

External arm

Level accuracy ± 0.5 V
Range ± 5 V
Input impedance 10 k Ω (typical)

HP 89441V Technical Data
RF

Source (requires internal RF source Option AY8)

Source types (vector mode and video demodulation)	CW (fixed sine), random noise
--	----------------------------------

Frequency

Range	2 MHz to 2650 MHz
-------	-------------------

Maximum offset from center frequency	3.5 MHz
---	---------

Amplitude (fixed sine source type)

Amplitude range	-40 dBm to +13 dBm
-----------------	--------------------

Typical maximum amplitude (overdrive is available using direct numeric entry)	+17 dBm
---	---------

Amplitude resolution	0.1 dB
----------------------	--------

Amplitude accuracy (source level \leq 13 dBm)

Source amplitude accuracy is the sum of absolute accuracy at the center frequency (zero offset frequency) and the IF flatness.

Absolute accuracy at the center frequency	20 ° - 30 °C	0 ° - 55 °C
	± 1.2 dB	± 3.5 dB

IF flatness (relative to center frequency)	± 1 dB	± 1.5 dB
---	------------	--------------

IF Flatness with offset frequency \leq 500 kHz	± 0.3 dB
---	--------------

Dynamic range (source level \leq dBm)

Harmonic distortion	< -40 dBc
---------------------	-------------

Non-harmonic spurious (within measurement bandwidth)	< -40 dBc
--	-------------

Average noise level (for offsets $>$ 1 MHz from the carrier and carrier frequency $>$ 100 MHz. For offsets $<$ 1 MHz, add the LO phase noise.)	< -120 dBc/Hz
---	-----------------

Crosstalk (source-to-receiver, source level \leq 0 dBm) < -80 dBfs

Source port
VSWR

Level ≤ -10 dBm	1.8:1 (11 dB return loss)
----------------------	---------------------------

Impedance

50 Ω (75 Ω with optional minimum-loss pad)

Connector

Type-N

Baseband

Baseband specifications apply with the receiver mode set to "IF section (0-10 MHz)" or "RF section (0-10 MHz)" unless noted otherwise. Specifications noted as "IF section only" apply with the receiver mode set to "IF section (0-10 MHz)" and the input signal connected directly to the IF section's channel 1 or channel 2 input.

Frequency

Frequency tuning (characteristic only)

Frequency range	dc to 10 MHz
Frequency span	1.0 Hz to 10 MHz
Center frequency tuning resolution	0.001 Hz
Number of frequency points/span	51 to 3201
Signal track (when enabled) keeps the largest measured signal at the center frequency.	

Frequency accuracy

Same as the RF specifications.

Frequency counter

Same as the RF specifications.

Stability (spectral purity)

Absolute and residual phase noise, $F_{in} = 10$ MHz (with standard high precision frequency reference or equivalent)

100 Hz offset	< -106 dBc/Hz
1 kHz offset	< -110 dBc/Hz
≥ 10 kHz offset	< -120 dBc/Hz

Phase noise decreases with decreasing input

$$\text{frequency by } 20 \log_{10} \left| \frac{F_{in}}{10 \text{ MHz}} \right| \text{ dB.}$$

Resolution bandwidth

Same as the RF specifications.

Amplitude

Input range (characteristic only)(2 dB steps)

50 Ω input	-30 dBm to +24 dBm
75 Ω input	-31.761 dBm to +22.239 dBm
1 M Ω input	-30 dBm to +28 dBm
(referenced to 50 Ω)	

Maximum safe input power

50 Ω /75 Ω input	+27 dBm
1 M Ω input	20 V Peak

Auto-ranging (characteristic only)

Up-only, up-down, single, off

Input port

Input channels	1 (second 10 MHz input channel optional)
Return loss (IF section only)	
50 Ω input	> 25 dB
75 Ω input	> 20 dB
Coupling	dc/ac (ac coupling attenuation < 3 dB at 3 Hz)
Input Impedance	50/75 Ω , 1 M Ω \pm 2%
(IF section only)	(< 80 pF shunt capacitance)
Connector	BNC (RF section: Type-N)

Amplitude accuracy

Accuracy specifications apply with flat-top window selected.

Amplitude accuracy is the sum of absolute full-scale accuracy and amplitude linearity.

Absolute full-scale accuracy (IF section only, with signal level equal to range)

± 0.5 dB

Amplitude linearity

0 to -30 dBfs < 0.10 dB

-30 to -50 dBfs < 0.15 dB

-50 to -70 dBfs < 0.20 dB

Residual dc (50 Ω) < -25 dBfs

HP 89441V Technical Data Baseband

Dynamic range

Dynamic range indicates the amplitude range that is free of erroneous signals within the measurement bandwidth.

Harmonic distortion (with a single full scale signal at the input)

2nd	< -75 dBc (-80 dBc typical)
3rd, 4th, 5th	< -75 dBc (-85 dBc typical)

Intermodulation distortion (with two input tones at 6 dB below full scale)

Second-order	< -75 dBc (-80 dBc typical)
Third-order	< -75 dBc (-85 dBc typical)

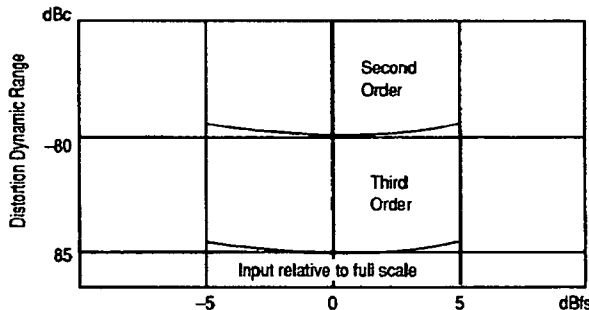

Typical harmonic and intermodulation distortion

Residual (spurious) responses (IF section only)
(50 Ω input and front panel connections to RF section disconnected)

Frequencies < 1 MHz	< -75 dBfs or < -100 dBm whichever is greater
Frequencies \geq 1 MHz	< -80 dBfs

Alias responses (for a single out-of-band tone at full scale) < -80 dBfs

Input noise density (50 Ω input, vector mode or scalar mode with sample detector)

1 kHz to 40 kHz	< -101 dBfs/Hz
40 kHz to 10 MHz	< -114 dBfs/Hz (-118 dBfs/Hz typical)

Sensitivity (-30 dBm range, 50 Ω input, vector mode or scalar mode with sample detector)

1 kHz to 40 kHz	< -131 dBm/Hz
40 kHz to 10 Hz	< -144 dBm/Hz (-148 dBm/Hz typical)

Crosstalk (source-to-input or channel-to-channel, 50 Ω terminations) < -85 dBfs

Phase (vector mode)

Phase specifications apply with flat-top window selected.

Deviation from linear phase (relative to best fit line with peak signal level within 6 dB of full scale) ± 5 deg

Time (vector mode)

Time-sample resolution = $1/(k \cdot \text{span}(\text{Hz}))$ [second]; where $k = 1.28$ for zoom time, 2.56 for baseband time measurements.

Main time length = $(\text{number of frequency points} - 1) \div \text{span}(\text{Hz})$ [second]; for resolution bandwidth in arbitrary and auto-coupled mode.

Amplitude accuracy (IF section only)(for a sine wave in the measurement passband, time-domain calibrations on) $\pm 5\%$ full scale

Sample error rate for zoom time (typical)
Error threshold: 10^{-8} times/sample
5% full scale

Sample error rate reflects the probability of an error greater than the error threshold occurring in one time sample.

Analog channel-to-channel time skew (IF section only) (time-domain calibrations on, both channels on the same range) < 1 ns

Two-channel

The second 10 MHz input channel (Option AY7) provides additional measurements, including frequency response, coherence, cross spectrum, and cross correlation. These measurements are made by comparing a signal on channel two to a signal on channel one or to a demodulated signal on the RF input.

Channel match ± 0.25 dB, ± 2.0 deg

(IF section only, at the center of the frequency bins, dc coupled, 16 rms averages, frequency response, full scale inputs, both inputs on the same range. Exclude the first 5 bins of the dc response.)

Trigger

Same as RF trigger specifications with the following additional specifications.

Input channel trigger (positive and negative slope)

Level accuracy $\pm 10\%$ full scale
Range $\pm 110\%$ full scale
Resolution Full scale/116 (typical)

Source

Source types

Scalar mode CW (fixed sine),
Vector mode and CW, random noise
video demodulation mode
Random noise source % of energy in-band $> 70\%$
(Span = $10 \text{ MHz}/2^N$, $N = 1$ to 24)

Frequency

Frequency range dc to 10 MHz
Frequency resolution 25 μHz

Amplitude

Source level
CW and -110 dBm to $+23.979$ dBm (50 Ω)
random noise 5.0 Vpk maximum

DC offset ± 3.42 V maximum (resolution and range of programmable dc offset is dependent on source amplitude)

Amplitude accuracy (50 Ω , fixed sine)
(IF section only)

-46 dBm to $+24$ dBm ± 1.0 dB
 -56 dBm to -46 dBm ± 2.0 dB

Harmonic and other spurious products (fixed sine, 0 V dc offset)

dc to 10 kHz < -55 dBc
10 kHz to 5 MHz < -40 dBc
5 MHz to 10 MHz < -33 dBc

Source port

Return loss (IF section only) > 20 dB
Source impedance 50/75 Ω

HP 89441V Technical Data
General

Safety and environmental

Safety standards	CSA Certified for Electronic Test and Measurement Equipment per CSA C22.2, No. 231
This product is designed for compliance to:	UL1244 and IEC348, 1978
Acoustics	LpA < 55 dB typical at 25 °C ambient (Temperature controlled fan to reduce noise output)
Temperature	
Operating	0 ° to 55 °C
Internal disk operations	4 ° to 40 °C
Storage (no disk in drive)	-20 ° to 65 °C
Humidity, non-condensing	
Operating	10% to 90% at 40 °C
Internal disk operations	20% to 80% at 30 °C
Storage (no disk in drive)	10% to 90% at 40 °C
Altitude	
Operating (above 2285 m (7,500 ft), derate operating temperature by -3.6 °C/1000 m (-1.1 °C/1000 ft))	4600 m (15,000 ft)
Storage	4600 m (15,000 ft)
Calibration interval	1 year
Warm-up time	30 minutes
Power requirements	
115 VAC operation	
IF section	90 - 140 Vrms, 47 - 440 Hz
RF section	90 - 140 Vrms, 47 - 63 Hz
230 VAC operation	198 - 264 Vrms, 47 - 63 Hz
Maximum power dissipation	
IF section	750 VA
RF section	275 VA

IEC 801-3 (Radiated Immunity) Performance degradation may occur at Severity Level 2.

Physical

Weight	IF section 25 kg (55 lb)	RF section 25 kg (55 lb)
Dimensions		
IF section	Height 230 mm (9.1 in)	Width 426 mm (16.7 in)
	Depth 530 mm (20.9 in)	
RF section	Height 173 mm (6.8 in)	Width 419 mm (16.5 in)
	Depth 495 mm (19.5 in)	

Real-time bandwidth (characteristics only)

Real-time bandwidth is the maximum frequency span that can be continually analyzed without missing any time segment of the input signal.

Frequency spans of $10^{7/2^n}$ Hz, arbitrary auto-coupled resolution bandwidth, markers off, one display trace with calculations off on other traces, and maximum frequency points equal to number of frequency points.

Averaging off

Single-channel vector mode (log magnitude spectrum measurement data, 1601 frequency points, channel 2 off, averaging off)	78.125 kHz, 48 updates/second
---	----------------------------------

Two-channel vector mode (requires second 10 MHz input channel, Option AY7) (Log magnitude frequency response measurement data, 801 frequency points, averaging off)	39.0625 kHz, 48 updates/second
---	-----------------------------------

Averaging

Single-channel vector mode averaging (log magnitude spectrum measurement data, 1601 frequency points, channel 2 off)

Fast average	78.125 kHz
Displayed	78.125 kHz, 48 updates/second

Two-channel vector mode averaging (requires second 10 MHz input channel, Option AY7) (Log magnitude frequency response measurement data, 801 frequency points)

Fast average	39.0625 kHz
Displayed	39.0625 kHz, 48 updates/second

Measurement speed

Display update speed (vector mode with full span, one or two channels, 401 frequency points, no averaging, markers off, single trace with calculations off on other traces, log magnitude spectrum, frequency spans of $10^{7/2^n}$ Hz): 60/second

Averaging (characteristics only)

Number of averages	1 to 99,999
Overlap averaging	0% to 99.99%
Average types	
Scalar mode	rms (video), rms (video) exponential, peak hold
Vector mode	rms (video), rms (video) exponential, time, time exponential, peak hold

Fast averaging allows averaging a user-defined number of measurements without updating the displayed result. This provides faster averaging results for most measurements.

Gating (characteristics only)

Time-selective, frequency-domain analysis can be performed on any input or analog demodulated time-domain data. When gating is enabled, markers appear on the time data; gate length and delay can be set directly. Independent gate delays can be set for each input channel. See time specifications for main time length and time resolution details.

Gate length

Maximum: Main time length

Minimum: Approximately window shape \div (0.3 \times span (Hz)) [seconds]; where window shape (ws) and minimum gate length for a 10 MHz zoom time span are (for 10 MHz baseband time spans subtract 39.0625 ns):

Window	ws	Minimum gate length
Flat-top	3.819	1.328125 μ s
Gaussian-top	2.215	781.25 ns
Hanning	1.5	546.875 ns
Uniform	1.0	390.625 ns

Time-capture (characteristics only)

Direct capture of input waveforms can be accomplished with spans of 10 MHz/2ⁿ Hz. See time specifications for time-sample resolution details.

Time capture memory: 64 Ksample; 1 Msample (Option AY9)

Benchmarks: For a one-channel, zoom time measurement (for baseband time, halve the time), 64 Ksample captures from 5.12 ms in a 10 MHz span to over 11.9 hours in a 1.19 Hz span. The optional 1 Msample captures from 81.92 ms in a 10 MHz span to over 190 hours in a 1.19 Hz span. Memory is shared if two channels are enabled, therefore length of capture is half as long.

Band power marker (characteristics only)

Markers can be placed on any time, frequency, or demodulated trace for direct computation of band power, rms square root (of power), C/N, and C/N₀ within the selected portion of the data.

Peak/Average statistics

Peak and peak-to-average statistics can be enabled on main time, gate time, IQ measured time, IQ reference time, and math functions involving these trace types. Average power and peak statistics are computed using all samples in the active trace. Each successive trace adds additional samples to the calculations.

Displayed results	average power peak power peak/average ratio number of samples
Peak percent	90% - 99.99%. Setting can be changed at any time during or after the measurement
Signal characteristics	
Peak power range	+ 13 dB relative to average power of the first time record
Average power range	+ 3 dB relative to average power of the first time record.

HP 89441V Technical Data

General

Display (characteristic only)

Trace formats	One to four traces on one, two, or four grids or a quad display
Other displays	On-line help text, view state
Number of colors	User-definable palette
Display points/trace	401
User-definable trace titles and information	
X-axis scaling	Allows expanded views of portions of the trace information
Display blanking	Data or full display
Graticule on/off	
Center	± 5 mm referenced to bezel opening
Dimensions	
Height	105 ± 5 mm
Width	147 ± 5 mm
Diagonal	180.6 mm (7.1 in)

Status indicators

Overload, half range, external trigger, source on/off, trigger, pause, active trace, remote, talk, listen, SRQ.

External PC-style keyboard interface

Compatible with PC-style 101-key keyboard, such as the HP C1405B with HP C1405-60015 adapter.

Interfaces (characteristics only)

Active probe power	+15 Vdc, -13 Vdc; 150 mA maximum, compatible with HP active probes
Sync out (not used)	Active low TTL level signal synchronous with source output of periodic chirps and arbitrary blocks up to 8192 samples.

External reference in/out IF section

External reference input Locks to a 1, 2, 5, or 10 MHz signal (± 10 ppm) with a level > 0 dBm

External reference output Output the same frequency as the external reference input at a level of > 0 dBm into a 50Ω load.

External reference in/out RF section

External reference input Locks to a 1, 2, 5, or 10 MHz signal (± 10 ppm) with a level > 0 dBm (use ≥ 5 dBm for optimum phase noise performance).

External reference output Outputs 10 MHz at > 0 dBm (+6 dBm typical) into a 50Ω load.

HP-IB

Implementation of IEEE Std 488.1 and 488.2
SH1, AH1, T6, TE0, L4, LE0, SRI, RL1, PP0, DC1, DT1, C1, C2, C3, C12, E2

Benchmark characteristics (typical transfer rate of 401 frequency-point traces)

Scalar	25 traces/second
Vector	20 traces/second
RS-232	Serial port (9-pin) for connection to printer
Centronics	Parallel port for connection to a printer

External monitor output

Format	Analog plug-compatible with 25.5 kHz multi-sync monitors
Impedance	75Ω
Level	0 to 0.7 V
Display rate	60 Hz
Horizontal refresh rate	25.5 kHz
Horizontal lines	400

Second HP-IB	Implementation of IEEE Std 488.1 and 488.2
LAN	ThinLAN BNC

Peripherals

Plot/print

Direct plotting and black-and-white printing to parallel (Centronics), serial (RS-232), and HP-IB graphics printers and plotters. Printers supported include the HP LaserJet, HP PaintJet, HP ThinkJet, HP DeskJet, and HP QuietJet. Single-plot spooling allows instrument operation while printing or plotting a single display.

Memory and data storage

Disk devices

Nonvolatile RAM disk	100 Kbytes
Volatile RAM disk	5 Mbytes that can be partitioned between measurement, HP Instrument BASIC program space and RAM.

Internal 90 mm (3.5-inch) flexible disk (HP LIF or MS-DOS® formats) 1.44 Mbyte

External disk HP-IB interface

Disk format and file delete, rename and copy

Nonvolatile clock with time/date

Save/recall can be used to store trace data, instrument states, trace math functions, HP Instrument BASIC programs, and time-capture buffers.

Benchmarks (typical disk space requirements for different file types)

Trace data (401 points)	6.2 Kbyte
Instrument state	12.3 Kbyte
Trace math	2 Kbyte
Time-capture buffers (32 Ksamples)	271 Kbyte

Trace math

Operands measurement data, data register, constant, other trace math functions, jw

Operations +, -, *, /, cross correlation, conjugate, magnitude, phase, real, imaginary, square root, FFT, inverse FFT, natural logarithm, exponential

Trace math can be used to manipulate data on each measurement. Uses include user-units correction and normalization.

Marker functions

Peak signal track, frequency counter, band power peak/average statistics.

Standard data format utilities

Included on two 90 mm (3.5-inch) 1.44 Mbyte flexible disks and two 130 mm (5.25-inch) 1.2 Mbyte floppy disks. The utilities run in MS-DOS® 2.1 or greater on an IBM PC (AT or higher) or compatible. The utilities include conversions to standard data format (SDF), PC displays of data and instrument state information, and utilities for conversion to PC-MATLAB, MATRIX_x, data set 58 and ACSII formats.

HP 89441V Technical Data General

Digital video modulation analysis

Supported modulation formats

Modulation formats	8 and 16VSB 16, 32, 64 and 256QAM 16, 32, and 64QAM (differentially encoded per DVB standard)
--------------------	---

Frequency span

The (2 - 2650 MHz)-wide receiver mode increases the maximum allowable vector frequency span to 8 MHz. Specifications for this mode are in the RF specification section.

Maximum symbol rate

The HP 89441V analyzes vector modulated signals up to a maximum symbol rate determined by the information bandwidth of the receiver mode and the excess bandwidth factor (α) of the input signal, according to:

$$\text{Max Symbol Rate} \leq \frac{\text{Information Bandwidth}}{1 + \alpha}$$

(Note: the maximum symbol rate is doubled for VSB signals.)

Receiver mode	Information bandwidth
ch1 + j*ch2	≤ 20 MHz *
0 - 10 MHz	≤ 10 MHz
2 - 2650 MHz - normal	≤ 7 MHz
2 - 2650 MHz - wide	≤ 8 MHz
External	≤ 10 MHz *

Example: For a 64 QAM signal ($\alpha = 0.15$), the maximum symbol rate for the (2-2650 MHz)-wide receiver is $8 \text{ MHz}/(1.15) = 6.96 \text{ Msymbols/second}$.

* Downconverter dependent.

Measurement results

I-Q measured (Filtered, carrier locked, symbol locked)	Time, spectrum
I-Q reference (Ideal, computed from detected symbols)	Time, spectrum
I-Q error vs. time (I-Q measured vs. reference)	Magnitude, phase
Error vector (Vector error of computed vs. reference)	Time, spectrum
Symbol table + error summary	Error vector magnitude is computed at symbol times only

Display formats

The following trace formats are available for measured data and computed ideal reference data, with complete marker and scaling capabilities and automatic grid line adjustment to ideal symbol or constellation states.

Polar diagrams

Constellation: Samples displayed only at symbol times

Vector: Display of trajectory only at symbol times with 1 to 20 points/symbol

I or Q vs time

Eye diagrams: Adjustable from 0.1 to 10 symbols

Trellis diagrams: Adjustable from 0.1 to 10 symbols

Continuous error vector magnitude vs. time

Continuous I or Q vs. time

Error summary

Measured rms and peak values of the following:

Error vector magnitude

Magnitude error

Phase error

Frequency error (carrier offset frequency)

I-Q offset

SNR and MER for QAM + VSB formats

VSB pilot level is shown, is dB relative to nominal.

For VSB formats, SNR is calculated from the real part of the error vector only.

For DVB formats, EVM is calculated without removing IQ offset.

Detected bits (symbol table)

Binary bits are displayed and grouped by symbols.

Multiple pages can be scrolled for viewing large data blocks.

Symbol marker (current symbol shown as inverse video) is coupled to measurement trace displays to identify states with corresponding bits.

Bits are user-definable for absolute states or differential transitions.

Accuracy

Residual errors (typical)

8VSB or 16VSB, symbol rate = 10.762 MHz,
 $\alpha = 0.115$, instrument receiver mode of IF 0-10 MHz
or RF 2 - 2650 MHz, 7 MHz span, full-scale signal,
range $\geq -25 \text{ dBm}$, result length = 800, averages = 10.

Residual EVM $\leq 1.5\%$ (SNR $\geq 36 \text{ dB}$)

16, 32, 64 or 256QAM, symbol rate = 6.9 MHz,
 $\alpha = 0.15$, instrument receiver mode of IF 0 - 10 MHz or
RF 2-2650 MHz - wide, 8 MHz span, full-scale signal,
range $\geq -25 \text{ dBm}$, result length = 800, averages = 10.

Residual EVM $\leq 1.0\%$ (SNR $\geq 40 \text{ dB}$)

Filtering

All filters are computed to 40 symbols in length

Filter types	Root Raised-Cosine
User-selectable filter parameters	Alpha continuously adjustable from 0.05 to 1.0

Adaptive equalization

The HP 89441V equalizes the digitally-modulated signal to remove effects of linear distortion (such as unflatness and group delay) in a modulation quality measurement.

Equalizer performance is a function of the filter design (e.g., length, convergence, taps/symbol) and the quality of the signal being equalized.

Equalizer

Decision-directed, LMS, feed-forward equalization with adjustable convergence rate.

Filter length	3 - 99 symbols, adjustable
Filter taps	1,2,4,5,10, or 20 taps/symbol

Measurement results

Equalizer impulse response
Channel frequency response

4 Mbytes Extended RAM and additional I/O

Extended RAM

Extended memory type: 4 Mbytes dynamic RAM
Approximately 6 Mbytes, user-allocatable to measurement memory, RAM disk and IBASIC program space.

LAN I/O

LAN support: Ethernet (IEEE 802.3) TCP/IP
LAN interface: ThinLAN (BNC connector) or AUI
Recommended MAU: HP 28685B (10base-T) or HP 28683A (FDDI)
Program interface: Send and receive HP-IB programming codes, status bytes and measurement results in ASCII and/or binary format.

HP-IB I/O

Secondary HP-IB port: Per IEEE Std 488.1 and 488.2
Functions: Controller-only; accessible from IBASIC program or front panel commands.

Advanced LAN support—Option UG7

Remote X11 display (characteristic only)
Update rate: > 20 per second, depending on workstation performance and LAN activity.
X11 R4 compatible
X-terminals, UNIX workstations, PC with X-server software
Display 640 x 480 pixel minimum resolution required; 1024 x 768 recommended.

FTP data (characteristic only)

Traces A, B, C, D
Data registers D1 - D6
Time capture buffer
Disk files (RAM, NVRAM, floppy disk)
Analyzer display plot/print